

ECE R118-4

ANNEX 10

TEST TO DETERMINE THE RESISTANCE TO FLAME PROPAGATION OF ELECTRICAL CABLES

1. SCOPE

This Annex defines prescriptions to test the resistance to flame propagation of electrical cables used in the vehicle.

2. SAMPLING AND PRINCIPLE

2.1. Five samples shall undergo the test

3. SAMPLES

3.1. Test samples shall have a length of at least 600mm of insulation.

4. PROCEDURE

Determine the resistance to flame propagation using a Bunsen burner with an appropriate gas, having a combustion tube of 9mm internal diameter, where the flame temperature at the tip of the inner blue cone shall be $(950 \pm 50)^\circ\text{C}$. Suspend the test sample in a draught-free chamber and expose the test sample to the tip of the inner cone of the flame, as shown in Figure 1. The upper end of the cable shall point away from the closest wall of the chamber. The sample shall be subject to a stress, e.g. by means of a weight over a pulley, in order to keep it straight at all times. The angle of the cable shall be $45 \pm 1^\circ$ relative to the vertical line. In any case, the shortest distance of any part of the sample shall be 100mm minimum from any wall of the chamber. Apply the flame with the tip of the inner blue cone touching the insulation (500 ± 5) mm from the upper end of the insulation.

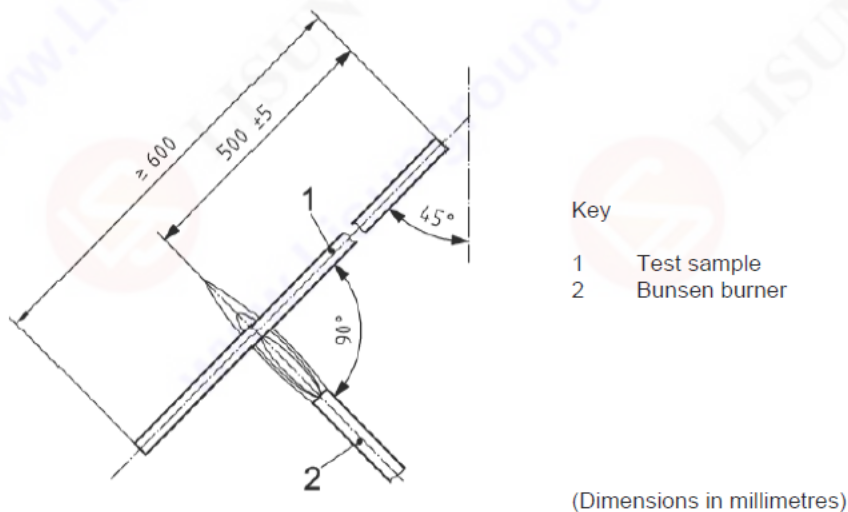

Figure 1

Apparatus for Resistance to Flame Propagation