



# 校准证书

## CALIBRATION CERTIFICATE

证书编号:

Certificate No.



1GA26042188234-0002

第 1 页 / 共 3 页

Page 1 of 3

委托方:

Client

DEKRA Certification B.V.

联络信息:

Contact Info

Meander 1051, 6825 MJ Arnhem, P.O. Box 5185, 6802 ED Arnhem, The Netherlands

仪器/样品名称:

Description

Uninsulated Live Parts Probe of UL1278 Fig 8.1

型号/规格:

Model/Type

SMT-PA130A

制造厂商:

Manufacturer

LISUN GROUP

出厂编号:

Serial No.

LS2026013602

管理号:

Asset No.

LS20260421A002

接收日期:

Date of Receipt

2026-04-21

校准日期:

Date of Calibration

2026-04-25

发布日期:

Issued Date

2026-04-25

建议再校日期:

Due Date

2027-04-24

结果:

Conclusion

按实测结果使用,见报告内页(Use according to the measured results, See the page of the report)

批准:

Approved by

韦寿前

韦寿前

审核:

Inspected by

林友春

林友春

校准:

Calibrated by

黄子铭

黄子铭



总部地址: 广东省广州市番禺区石碁镇农科所南街8号

Headquarters Add: No.8.South Street Shi Ji Institute Guangzhou.Guangdong.China

实验室地址: 广东省广州市番禺区石碁镇农科所南街8号

Add of Lab: No.8.South Street Shi Ji Institute Guangzhou.Guangdong.China

联系电话(Tel): 020-31134076

投诉电话(CT): 020-39969860

编码(Post): 511400

传真(Fax): 020-39969986

网址(Web): www.lisaitest.com

邮件(E-mail): cal@lisaitest.com

校验码:A26651DF

我司电子证书具备网站查验、微信公众号查验(二维码扫码查验)、校验码、电子签章、骑缝章多重防伪验证。





证书编号:

1GA26042188234-0002

校准说明

第 2 页 / 共 3 页

Certificate No.

Directions of Calibration

Page 2 of 3

1. 本实验室质量管理体系符合ISO/IEC17025标准要求。本实验室出具的数据均可溯源至国际单位制(SI)和社会公用计量标准。

The quality system is in accordance with ISO/IEC17025. All data issued by this laboratory are traceable to International System of Units(SI) and public measurement standards.

2. 本结果仅与受校准/检测样品有效。未经实验室批准,不得部分复制。如有疑问请在15个工作日内反馈。

The results relate only to the items calibrated/tested.This certificate shall not be reproduced except in full,without the written approval of our laboratory. Please feedback to us within 15 days if you have any question.

3. 本证书编号具有唯一性,后缀若带有"A~Z"的证书为替换证书,自发出后原证书即刻作废。

Each certificate has a unique number,The suffix of "A~Z" will be added to the number as a replacement of the old version. The original certificate will be officially invalid once the new certificate number is issued.

4. 内页中最大允许误差、判定结果仅供参考,其中"P"代表"合格","F"代表"不合格","N/A"代表"不适用"。使用人员应结合实际测量需求,评估测量不确定度对符合性评定的影响。

MPE & judgement result in the datasheet is only for reference,"P" represents "Pass" and "F" represents "Fail" and "N/A" represents "Not Applicable".Where as users should evaluate the effects of MU of calibration results on conformance assessment by actual measurement.

5. 校准地点、环境条件(Place and environmental condition of the Calibration):

地点(Place): 广州实验室(101精测室)

温度(Temperature): 20.2°C 相对湿度(Relative Humidity): 65 %

6. 本次校准的技术依据(Reference documents for the Calibration):

JJF(辽)288-2016 外壳对人和设备的防护检验用试具校准规范 Calibration Specification for Protection of person and equipment by enclosures-Probe for verification

7. 计量溯源性声明(Measurement traceability declaration):

被校器具 (Description) : Uninsulated Live Parts Probe of UL1278 Fig 8.1; 被校器具 (Description) → 影像测量仪(Image Measuring Instrument) → 玻璃线纹尺(Glass line ruler) → 华南国家计量测试中心(South China National Center of Metrology); 被校器具 (Description) → 数显卡尺(Digital Caliper) → 卡尺量块/量块(112块)→量块(83块)(Caliper Gauge Block/Gauge block→Measuring block) → 华南国家计量测试中心(South China National Center of Metrology)

8. 本次校准使用的主要标准器具(Main standards of measurement used in the Calibration):

名称/型号 Equipment/Model	出厂编号 Serial No.	证书号/有效期 Cert No./ Due Date	溯源机构 Traceability Institute	技术特征 Technique Character
影像测量仪/vGauge 30M15 Image Measuring Instrument	NE- M-14-260	3GC25121255935-64 63 / 2026-12-25	广州力赛计量检测有限公司 (Guangzhou Lisai Metrology & Test Co.,Ltd.)	$U=(1.8+3L/1000)\mu\text{m} (k=2)$
数显卡尺/(0~300)mm Digital Caliper	K18A305749	3GC25121255935-75 09 / 2026-12-24	广州力赛计量检测有限公司 (Guangzhou Lisai Metrology & Test Co.,Ltd.)	(0~70)mm,MPE=±0.02mm; (>70~200)mm,MPE=±0.03mm; (>200~300)mm,MPE=±0.04mm



证书编号: 1GA26042188234-0002

**校准结果**

第 3 页 / 共 3 页

Certificate No.

**Results of Calibration**

Page 3 of 3

1、外观以及一般性检查: 正常  
 In view of External and Generality check : Pass

2、尺寸校准(Dimensional calibration):

2.1、示意图 (Diagram)

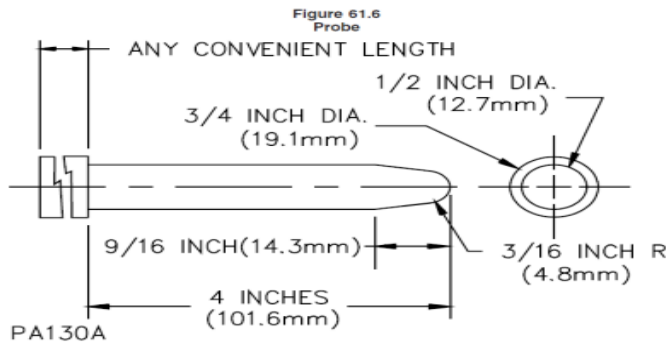

2.2、尺寸校准(Dimensional calibration):

标称值 Nominal (mm)	实测值 Measured (mm)	$U$ ( $k=2$ ) (mm)
101.6	101.63	0.04
14.3	14.35	0.03
4.8	4.75	0.03
19.1	19.11	0.03
12.7	12.66	0.03

附: 关于测量结果不确定度的说明:  
 Appendix: Directions of uncertainty in the calibration

1.依据(Reference document)

JJF 1059.1-2012测量不确定度评定与表示

(JJF 1059.1-2012 Evaluation and Expression of Uncertainty in Measurement)

2.本报告给出的扩展不确定度是由合成标准不确定度乘以包含概率约为95%时对应的包含因子k得到的。

The expanded uncertainty given in this report is obtained by multiplying the combined standard uncertainty by the corresponding coverage factor k when the coverage probability of about 95%.

以下空白(The below is blank)

