

Electromagnetic compatibility (EMC) —

Part 4-2: Testing and measurement techniques — Electrostatic discharge immunity test

www.lisungroup.com

The European Standard EN 61000-4-2:1995, with the incorporation of amendments A1:1998 and A2:2001 has the status of a British Standard

ICS 33.100

Committees responsible for this British Standard

The preparation of this British Standard was entrusted by Technical Committee GEL/110, Electromagnetic compatibility, to Subcommittee GEL/110/10, Electromagnetic compatibility — High frequency disturbances, upon which the following bodies were represented:

Association of Consulting Scientists
 Association of Manufacturers of Domestic Electrical Appliances
 British Telecommunications plc
 ERA Technology Ltd.
 Electrical Installation Equipment Manufacturers' Association (BEAMA Ltd.)
 Federation of the Electronics Industry
 Lighting Industry Federation Ltd.
 Power Supply Manufacturers' Association — PSMA (BEAMA Ltd.)
 Radiocommunications Agency
 Sound and Communications Industries' Federation

www.Lisungroup.co

This British Standard, having been prepared under the direction of the Electrotechnical Sector Board, was published under the authority of the Standards Board and comes into effect on 15 September 1995

© BSI 28 September 2001

The following BSI references relate to the work on this standard:
 Committee reference GEL/110/10
 Draft for comment 93/20234 DC

Amendments issued since publication

| Amd. No. | Date | Comments |
|----------|-------------------|---------------------------------|
| 10112 | January 1999 | New 8.3.2.1 and Figure 5 |
| 13187 | 28 September 2001 | See national foreword |
| | | |
| | | |

Contents

| | Page |
|------------------------|--------------------|
| Committees responsible | Inside front cover |
| National foreword | ii |
| Foreword | 2 |
| Text of EN 61000-4-2 | 5 |

www.Lisungroup.cc

National foreword

This British Standard has been prepared by Subcommittee GEL/110/10 and is the English language version of EN 61000-4-2:1995 *Electromagnetic compatibility (EMC) — Part 4-2: Testing and measurement techniques — Electrostatic discharge immunity test*, including amendments A1:1998 and A2:2001, published by the European Committee for Electrotechnical Standardization (CENELEC). It is identical with IEC 61000-4-2:1995 including amendments 1:1998 and 2:2000 published by the International Electrotechnical Commission (IEC).

The start and finish of text introduced or altered by amendment is indicated in the text by tags $\overline{A_1}$ $\overline{A_1}$. Tags indicating changes to IEC text carry the number of the IEC amendment. For example, text altered by IEC amendment 2 is indicated by $\overline{A_2}$ $\overline{A_2}$.

IEC 61000 has been designated a Basic EMC Publication for use in the preparation of dedicated product, product family and generic EMC standards.

IEC 61000 will be published in separate Parts in accordance with the following structure.

- Part 1: *General — General considerations (introduction, fundamental principles) — Definitions, terminology;*
- Part 2: *Environment — Description of the environment — Classification of the environment — Compatibility levels;*
- Part 3: *Limits — Emission limits — Immunity limits (in so far as they do not fall under the responsibility of the product committees);*
- Part 4: *Testing and measurement techniques — Measurement techniques — Testing techniques;*
- Part 5: *Installation and mitigation guidelines — Installation guidelines — Mitigation methods and devices;*
- Part 9: *Miscellaneous.*

Each Part will be subdivided into Sections each of which may be published as either a standard or a Technical Report.

From 1 January 1997, all IEC publications have the number 60000 added to the old number. For instance, IEC 27-1 has been renumbered as IEC 60027-1. For a period of time during the change over from one numbering system to the other, publications may contain identifiers from both systems.

Cross-references

The British Standards which implement international or European publications referred to in this document may be found in the BSI Standards Catalogue under the section entitled “International Standards Correspondence Index” or by using the “Find” facility of the BSI Standards Electronic Catalogue.

A British Standard does not purport to include all the necessary provisions of a contract. Users of British Standards are responsible for their correct application.

Compliance with a British Standard does not of itself confer immunity from legal obligations.

Summary of pages

This document comprises a front cover, an inside front cover, pages i and ii, the EN title page, pages 2 to 33 and a back cover.

The BSI copyright notice displayed in this document indicates when the document was last issued.

ICS 29.020

Descriptors: electric equipment, electronic equipment, electromagnetic compatibility, electrostatic protection, electrostatic discharge tests, characteristics, testing conditions

English version

Electromagnetic compatibility (EMC) —
Part 4-2: Testing and measurement techniques —
Electrostatic discharge immunity test

(includes amendments A1:1998 and A2:2001)
(IEC 61000-4-2:1995 + A1:1998 + A2:2000)

Compatibilité électromagnétique (CEM) —
Partie 4-2: Techniques d'essai et de mesure —
Essais d'immunité aux décharges
électrostatiques
(inclut les amendements A1:1998 et A2:2001)
(CEI 61000-4-2:1995 + A1:1998 + A2:2000)

Elektromagnetische Verträglichkeit (EMV) —
Teil 4-2: Prüf- und Meßverfahren —
Prüfung der Störfestigkeit gegen die Entladung
statischer Elektrizität
(enthält Änderungen A1:1998 und A2:2001)
(IEC 61000-4-2:1995 + A1:1998 + A2:2000)

This European Standard was approved by CENELEC on 1995-03-06; amendment A1 was approved by CENELEC on 1998-04-01 and amendment A2 was approved by CENELEC on 2000-12-01. CENELEC members are bound to comply with the CENELEC Internal Regulations which stipulate the conditions for giving this European Standard the status of a national standard without any alteration.

Up-to-date lists and bibliographical references concerning such national standards may be obtained on application to the Central Secretariat or to any CENELEC member.

This European Standard exists in three official versions (English, French, German). A version in any other language made by translation under the responsibility of a CENELEC member into its own language and notified to the Central Secretariat has the same status as the official versions.

CENELEC members are the national electrotechnical committees of Austria, Belgium, Denmark, Finland, France, Germany, Greece, Iceland, Ireland, Italy, Luxembourg, Netherlands, Norway, Portugal, Spain, Sweden, Switzerland and United Kingdom.

CENELEC

European Committee for Electrotechnical Standardization
Comité Européen de Normalisation Electrotechnique
Europäisches Komitee für Elektrotechnische Normung

Central Secretariat: rue de Stassart 35, B-1050 Brussels

Foreword

The text of document 77B(CO)21, future edition 1 of IEC 1000-4-2, prepared by SC 77B, High-frequency phenomena, of IEC TC 77, Electromagnetic compatibility, was submitted to the IEC-CENELEC parallel vote and was approved by CENELEC as EN 61000-4-2 on 1995-03-06.

The following dates were fixed:

- latest date by which the EN has to be implemented at national level by publication of an identical national standard or by endorsement (dop) 1996-03-01
- latest date by which the national standards conflicting with the EN have to be withdrawn (dow) 1996-03-01

Annexes designated “normative” are part of the body of the standard. Annexes designated “informative” are given for information only. In this standard, Annex ZA is normative and Annex A and Annex B are informative. Annex ZA has been added by CENELEC.

Foreword to amendment A1

The text of document 77B/216/FDIS, future amendment 1 to IEC 61000-4-2:1995, prepared by SC 77B, High-frequency phenomena, of IEC TC 77, Electromagnetic compatibility, was submitted to the IEC-CENELEC parallel vote and was approved by CENELEC as amendment A1 to EN 61000-4-2:1995 on 1998-04-01.

The following dates were fixed:

- latest date by which the amendment has to be implemented at national level by publication of an identical national standard or by endorsement (dop) 1999-01-01
- latest date by which the national standards conflicting with the amendment have to be withdrawn (dow) 2001-01-01

Foreword to amendment A2

The text of documents 77B/291 + 292/FDIS, future amendment 2 to IEC 61000-4-2:1995, prepared by SC 77B, High-frequency phenomena, of IEC TC 77, Electromagnetic compatibility, was submitted to the IEC-CENELEC parallel vote and was approved by CENELEC as amendment A2 to EN 61000-4-2:1995 on 2000-12-01.

The following dates were fixed:

- latest date by which the amendment has to be implemented at national level by publication of an identical national standard or by endorsement (dop) 2001-09-01
- latest date by which the national standards conflicting with the amendment have to be withdrawn (dow) 2003-12-01

Contents

| | Page | Page |
|---|--------------|---|
| Foreword | 2 | |
| Introduction | 5 | |
| 1 Scope | 5 | |
| 2 Normative references | 5 | |
| 3 General | 6 | |
| 4 Definitions | 6 | |
| 5 Test levels | 7 | |
| 6 Test generator | 8 | |
| 6.1 Characteristics and performance of the ESD generator | 8 | |
| 6.2 Verification of the characteristics of the ESD generator | 9 | |
| 7 Test set-up | 9 | |
| 7.1 Test set-up for tests performed in laboratories | 10 | |
| 7.2 Test set-up for post-installation tests | 12 | |
| 8 Test procedure | 12 | |
| 8.1 Laboratory reference conditions | 12 | |
| 8.2 EUT exercising | 12 | |
| 8.3 Execution of the test | 13 | |
| 9 A2 Evaluation of test results | 15 | |
| 10 Test report | 15 A2 | |
| Annex A (informative) Explanatory notes | 24 | |
| Annex B (informative) Constructional details | 27 | |
| Annex ZA (normative) Other international publications quoted in this standard with the references of the relevant European publications | 33 | |
| Figure 1 — Simplified diagram of the ESD generator | 16 | |
| Figure 2 — Example of arrangement for verification of ESD generator performance | 17 | |
| Figure 3 — Typical waveform of the output current of the ESD generator | 18 | |
| Figure 4 — Discharge electrodes of the ESD generator | 19 | |
| Figure 5 — Example of test set-up for tabletop equipment — Laboratory tests | 20 | |
| Figure 6 — Example of test set-up for floor-standing equipment — Laboratory tests | 21 | |
| Figure 7 — Example of test set-up for floor-standing equipment, post-installation tests | 22 | |
| A2 Figure 8 — Test set-up for ungrounded tabletop equipment | 22 | |
| | | Figure 9 — Test set-up for ungrounded floor-standing equipment 23 A2 |
| | | Figure A.1 — Maximum values of electrostatic voltages to which operators may be charged while in contact with the materials mentioned in clause A.2 26 |
| | | Figure B.1 — Constructional details of the resistive load 28 |
| | | Figure B.2 29 |
| | | Figure B.3 30 |
| | | Figure B.4 31 |
| | | Figure B.5 31 |
| | | Figure B.6 32 |
| | | Figure B.7 32 |
| | | Table 1 — Test levels 8 |
| | | Table 2 — Waveform parameters 9 |
| | | Table A.1 — Guideline for the selection of the test levels 25 |

www.Lisungroup.cc

Introduction

IEC 1000-4 is a part of the IEC 1000 series, according to the following structure:

Part 1: General — General considerations (introduction, fundamental principles) — Definitions, terminology;

Part 2: Environment — Description of the environment — Classification of the environment — Compatibility levels;

Part 3: Limits — Emission limits — Immunity limits (in so far as they do not fall under the responsibility of the product committees);

Part 4: Testing and measurement techniques — Measurement techniques — Testing techniques;

Part 5: Installation and mitigation guidelines — Installation guidelines — Mitigation methods and devices;

Part 9: Miscellaneous.

Each part is further subdivided into sections which are to be published either as international standards or as technical reports.

These sections of IEC 1000-4 will be published in chronological order and numbered accordingly.

This section is an international standard which gives immunity requirements and test procedures related to “electrostatic discharge”.

1 Scope

This International Standard relates to the immunity requirements and test methods for electrical and electronic equipment subjected to static electricity discharges, from operators directly, and to adjacent objects. It additionally defines ranges of test levels which relate to different environmental and installation conditions and establishes test procedures.

The object of this standard is to establish a common and reproducible basis for evaluating the performance of electrical and electronic equipment when subjected to electrostatic discharges. In addition, it includes electrostatic discharges which may occur from personnel to objects near vital equipment.

This standard defines:

- typical waveform of the discharge current;
- range of test levels;
- test equipment;
- test set-up;
- test procedure.

This standard gives specifications for tests performed in “laboratories” and “post-installation tests” performed on equipment in the final installation.

This standard does not intend to specify the tests to be applied to particular apparatus or systems. Its main aim is to give a general basic reference to all concerned product committees of the IEC. The product committees (or users and manufacturers of equipment) remain responsible for the appropriate choice of the tests and the severity level to be applied to their equipment.

In order not to impede the task of coordination and standardization, the product committees or users and manufacturers are strongly recommended to consider (in their future work or revision of old standards) the adoption of the relevant immunity tests specified in this standard.

2 Normative references

The following normative documents contain provisions which, through reference in this text, constitute provisions of this section of IEC 1000-4. At the time of publication, the editions indicated were valid. All normative documents are subject to revision, and parties to agreements based on this section of IEC 1000-4 are encouraged to investigate the possibility of applying the most recent editions of the normative documents indicated below. Members of IEC and ISO maintain registers of currently valid International Standards.

IEC 50(161):1990, *International Electrotechnical Vocabulary (IEV) — Chapter 161: Electromagnetic compatibility.*

IEC 68-1:1988, *Environmental testing — Part 1: General and guidance.*

3 General

This standard relates to equipment, systems, sub-systems and peripherals which may be involved in static electricity discharges owing to environmental and installation conditions, such as low relative humidity, use of low-conductivity (artificial fibre) carpets, vinyl garments, etc., which may exist in allocations classified in standards relevant to electrical and electronic equipment (for more detailed information, see clause A.1 of Annex A).

The tests described in this standard are considered to be a first step in the direction of commonly used tests for the qualitative evaluation of the performance of all electrical and electronic equipment as referred to in clause 1.

NOTE From the technical point of view the precise term for the phenomenon would be "static electricity discharge". However, the term "electrostatic discharge" (ESD) is widely used in the technical world and in technical literature. Therefore, it has been decided to retain the term ESD in the title of this standard.

4 Definitions

For the purpose of this section of IEC 1000-4, the following definitions and terms apply and are applicable to the restricted field of electrostatic discharge; not all of them are included in IEC 50(161) [IEV].

4.1

degradation (of performance)

an undesired departure in the operational performance of any device, equipment or system from its intended performance
[IEV 161-01-19]

NOTE The term "degradation" can apply to temporary or permanent failure.

4.2

electromagnetic compatibility (EMC)

the ability of an equipment or system to function satisfactorily in its electromagnetic environment without introducing intolerable electromagnetic disturbances to anything in that environment
[IEV 161-01-07]

4.3

antistatic material

material exhibiting properties which minimize charge generation when rubbed against or separated from the same or other similar materials

4.4

energy storage capacitor

the capacitor of the ESD-generator representing the capacity of a human body charged to the test voltage value. This may be provided as a discrete component, or a distributed capacitance

4.5

ESD

electrostatic discharge (see 4.10)

4.6

EUT

equipment under test

4.7

ground reference plane (GRP)

a flat conductive surface whose potential is used as a common reference
[IEV 161-04-36]

4.8

coupling plane

a metal sheet or plate, to which discharges are applied to simulate electrostatic discharge to objects adjacent to the EUT. HCP: Horizontal Coupling Plane; VCP: Vertical Coupling Plane

4.9**holding time**

interval of time within which the decrease of the test voltage due to leakage, prior to the discharge, is not greater than 10 %

4.10**electrostatic discharge; ESD**

a transfer of electric charge between bodies of different electrostatic potential in proximity or through direct contact

[IEV 161-01-22]

4.11**immunity (to a disturbance)**

the ability of a device, equipment or system to perform without degradation in the presence of an electromagnetic disturbance

[IEV 161-01-20]

4.12**contact discharge method**

a method of testing, in which the electrode of the test generator is held in contact with the EUT, and the discharge actuated by the discharge switch within the generator

4.13**air discharge method**

a method of testing, in which the charged electrode of the test generator is brought close to the EUT, and the discharge actuated by a spark to the EUT

4.14**direct application**

application of the discharge directly to the EUT

4.15**indirect application**

application of the discharge to a coupling plane in the vicinity of the EUT, and simulation of personnel discharge to objects which are adjacent to the EUT

5 Test levels

The preferential range of test levels for the ESD test is given in Table 1.

Testing shall also be satisfied at the lower levels given in Table 1.

Details concerning the various parameters which may influence the voltage level to which the human body may be charged are given in clause A.2 of Annex A. Clause A.4 also contains examples of the application of the test levels related to environmental (installation) classes.

Contact discharge is the preferred test method. Air discharges shall be used where contact discharge cannot be applied. Voltages for each test method are given in Tables 1a and 1b. The voltages shown are different for each method due to the differing methods of test. It is not intended to imply that the test severity is equivalent between test methods.

Further information is given in clauses A.3, A.4 and A.5 of Annex A.

Table 1 — Test levels

| 1a – Contact discharge | | 1b – Air discharge | |
|------------------------|--------------------|--------------------|--------------------|
| Level | Test voltage kV | Level | Test voltage kV |
| 1 | 2 | 1 | 2 |
| 2 | 4 | 2 | 4 |
| 3 | 6 | 3 | 8 |
| 4 | 8 | 4 | 15 |
| x ^a | Special | x ^a | Special |

^a “x” is an open level. The level has to be specified in the dedicated equipment specification. If higher voltages than those shown are specified, special test equipment may be needed.

6 Test generator

The test generator consists, in its main parts, of:

- charging resistor R_c ;
- energy-storage capacitor C_s ;
- distributed capacitance C_d ;
- discharge resistor R_d ;
- voltage indicator;
- discharge switch;
- interchangeable tips of the discharge electrode (see Figure 4);
- discharge return cable;
- power supply unit.

A simplified diagram of the ESD generator is given in Figure 1. Constructional details are not given.

The generator shall meet the requirements given in 6.1 and 6.2.

6.1 Characteristics and performance of the ESD generator

Specifications

- energy storage capacitance ($C_s + C_d$): 150 pF \pm 10 %;
- discharge resistance (R_d): 330 Ω \pm 10 %;
- charging resistance (R_c): between 50 M Ω and 100 M Ω ;
- output voltage (see note 1): up to 8 kV (nominal) for contact discharge;
up to 15 kV (nominal) for air discharge;
- tolerance of the output voltage indication: \pm 5 %;
- polarity of the output voltage: positive and negative (switchable);
- holding time: at least 5 s;
- discharge, mode of operation (see note 2): single discharge (time between successive discharges at least 1 s);
- waveshape of the discharge current: see 6.2.

NOTE 1 Open circuit voltage measured at the energy storage capacitor.

NOTE 2 The generator should be able to generate at a repetition rate of at least 20 discharges per second for exploratory purposes only.

The generator shall be provided with means of preventing unintended radiated or conducted emissions, either of pulse or continuous type, so as not to disturb the EUT or auxiliary test equipment by parasitic effects.

The energy storage capacitor, the discharge resistor, and the discharge switch shall be placed as close as possible to the discharge electrode.

The dimensions of the discharge tips are given in Figure 4.

For the air discharge test method the same generator is used and the discharge switch has to be closed. The generator shall be fitted with the round tip shown in Figure 4.

The discharge return cable of the test generator shall be in general 2 m long, and constructed to allow the generator to meet the waveform specification. It shall be sufficiently insulated to prevent the flow of the discharge current to personnel or conducting surfaces, other than via its termination, during the ESD test.

In cases where a 2 m length of the discharge return cable is insufficient, (e.g. for tall EUTs), a length not exceeding 3 m may be used, but compliance with the waveform specification shall be verified.

6.2 Verification of the characteristics of the ESD generator

In order to compare the test results obtained from different test generators, the characteristics shown in Table 2 shall be verified using the discharge return cable to be used in the testing.

Table 2 — Waveform parameters

| Level | Indicated voltage kV | First peak current of discharge $\pm 10\%$ A | Rise time t_r with discharge switch ns | Current ($\pm 30\%$) at 30 ns A | Current ($\pm 30\%$) at 60 ns A |
|-------|-------------------------|---|---|--------------------------------------|--------------------------------------|
| 1 | 2 | 7,5 | 0,7 to 1 | 4 | 2 |
| 2 | 4 | 15 | 0,7 to 1 | 8 | 4 |
| 3 | 6 | 22,5 | 0,7 to 1 | 12 | 6 |
| 4 | 8 | 30 | 0,7 to 1 | 16 | 8 |

The waveform of the output current of the ESD generator during the verification procedure shall conform to Figure 3.

The values of the characteristics of the discharge current shall be verified with 1 000 MHz bandwidth measuring instrumentation.

A lower bandwidth implies limitations in the measurement of rise time and amplitude of the first current peak.

For verification, the tip of the discharge electrode shall be placed in direct contact with the current-sensing transducer, and the generator operated in the contact discharge mode.

The typical arrangement for the verification of the ESD generator performance is given in Figure 2. The bandwidth of the target has to be more than 1 GHz. Constructional details of a possible design for the current-sensing transducer are given in Annex B.

Other arrangements that imply the use of a laboratory Faraday cage having dimensions different from those in Figure 2 are allowed; separation of the Faraday cage from the target plane is also allowed, but in both cases the distance between the sensor and the grounding terminal point of the ESD generator shall be respected (1 m), as well as the layout of the discharge return cable.

The ESD generator shall be recalibrated in defined time periods in accordance with a recognized quality assurance system.

7 Test set-up

The test set-up consists of the test generator, EUT and auxiliary instrumentation necessary to perform direct and indirect application of discharges to the EUT in the following manner:

- a) contact discharge to the conductive surfaces and to coupling planes;
- b) air discharge at insulating surfaces.

Two different types of tests can be distinguished:

- type (conformance) tests performed in laboratories;
- post installation tests performed on equipment in its final installed conditions.

The preferred test method is that of type tests performed in laboratories.

The EUT shall be arranged in accordance with the manufacturer's instructions for installation (if any).

7.1 Test set-up for tests performed in laboratories

The following requirements apply to tests performed in laboratories under environmental reference conditions outlined in 8.1.

A ground reference plane shall be provided on the floor of the laboratory. It shall be a metallic sheet (copper or aluminium) of 0,25 mm minimum thickness; other metallic materials may be used but they shall have at least 0,65 mm minimum thickness.

The minimum size of the reference plane is 1 m², the exact size depending on the dimensions of the EUT. It shall project beyond the EUT or coupling plane by at least 0,5 m on all sides, and shall be connected to the protective grounding system.

Local safety regulations shall always be met.

The EUT shall be arranged and connected according to its functional requirements.

A distance of 1 m minimum shall be provided between the equipment under test and the walls of the laboratory and any other metallic structure.

The EUT shall be connected to the grounding system, in accordance with its installation specifications. No additional grounding connections are allowed.

The positioning of the power and signal cables shall be representative of installation practice.

The discharge return cable of the ESD generator shall be connected to the ground reference plane. The total length of this cable is in general 2 m.

In cases where this length exceeds the length necessary to apply the discharges to be selected points, the excess length shall, where possible, be placed non-inductively off the ground reference plane and shall not come closer than 0,2 m to other conductive parts in the test set-up.

The connection of the earth cables to the ground reference plane and all bondings shall be of low impedance, for example by using clamping devices for high frequency applications.

Where coupling planes are specified, for example to allow indirect application of the discharge, they shall be constructed from the same material type and thickness as that of the ground reference plane, and shall be connected to the GRP via a cable with a 470 k Ω resistor located at each end. These resistors shall be capable of withstanding the discharge voltage and shall be insulated to avoid short circuits to the GRP when the cable lies on the GRP.

Additional specifications for the different types of equipment are given below.

7.1.1 Tabletop equipment

The test set-up shall consist of a wooden table, 0,8 m high, standing on the ground reference plane.

A horizontal coupling plane (HCP), 1,6 m \times 0,8 m, shall be placed on the table. The EUT and cables shall be isolated from the coupling plane by an insulating support 0,5 mm thick.

If the EUT is too large to be located 0,1 m minimum from all sides of the HCP, an additional, identical HCP shall be used, placed 0,3 m from the first, with the short sides adjacent. The table has to be enlarged or two tables may be used. The HCPs shall not be bonded together, other than via resistive cables to the GRP.

Any mounting feet associated with the EUT shall remain in place.

An example of the test set-up for tabletop equipment is given in Figure 5.

7.1.2 Floor-standing equipment

The EUT and cables shall be isolated from the ground reference plane by an insulating support about 0,1 m thick.

An example of the test set-up for floor-standing equipment is given in Figure 6.

Any mounting feet associated with the EUT shall remain in place.

A2) 7.1.3 Test method for ungrounded equipment

The test method described in this subclause is applicable to equipment or part(s) of equipment whose installation specifications or design preclude connection to any grounding system. Equipment, or parts thereof, includes portable, battery-operated and double-insulated equipment (class II equipment).

Rationale: Ungrounded equipment, or ungrounded part(s) of equipment, cannot discharge itself similarly to class I mains-supplied equipment. If the charge is not removed before the next ESD pulse is applied, it is possible that the EUT or part(s) of the EUT be stressed up to twice the intended test voltage. Therefore, double-insulated equipment could be charged at an unrealistically high charge, by accumulating several ESD discharges on the capacitance of the class II insulation, and then discharge at the breakdown voltage of the insulation with a much higher energy.

The general test set-up shall be identical to the ones described in 7.1.1 and 7.1.2 respectively.

To simulate a single ESD event (either by air or by contact discharge), the charge on the EUT shall be removed prior to each applied ESD pulse.

The charge on the metallic point or part to which the ESD pulse is to be applied, for example, connector shells, battery charge pins, metallic antennae, shall be removed prior to each applied ESD test pulse.

When one or several metallic accessible parts are subject to the ESD test, the charge shall be removed from the point where the ESD pulse is to be applied, as no guarantee can be given about the resistance between this and other accessible points on the product.

A cable with 470 k Ω bleeder resistors, similar to the one used with the horizontal and vertical coupling planes, shall be used; see 7.1.

As the capacitance between EUT and HCP (tabletop) and between EUT and GRP (floor-standing) is determined by the size of the EUT, the cable with bleeder resistors may remain installed during the ESD test when functionally allowed. In the discharge cable, one resistor shall be connected as close as possible, preferably less than 20 mm from the EUT test point. The second resistor shall be connected near the end of the cable attached to the HCP for tabletop equipment (see Figure 8), or GRP for floor-standing equipment (see Figure 9).

The presence of the cable with the bleeder resistors can influence the test results of some equipment. In case of dispute, a test with the cable disconnected during the ESD pulse takes precedence over the test with the cable installed during the test, provided that the charge has sufficiently decayed between the successive discharges.

As an alternative, the following options can be used:

- the time interval between successive discharges shall be extended to the time necessary to allow natural decay of the charge from the EUT;
- a carbon fibre brush with bleeder resistors (for example, 2 \times 470 k Ω) in the grounding cable;
- an air-ionizer to speed-up the “natural” discharging process of the EUT to its environment.

The ionizer shall be turned off when applying an air-discharge test. The use of any alternative method shall be reported in the test report.

NOTE In case of dispute concerning the charge decay, the charge on the EUT can be monitored by a non-contacting electric field meter. When the charge has decayed below 10 % of the initial value, the EUT is considered to be discharged.

The tip of the ESD generator shall be held normal (perpendicular) to the surface of the EUT.

7.1.3.1 Tabletop equipment

For tabletop equipment, the EUT is placed on the horizontal coupling plane on top of the insulating foil (0,5 mm thick), as described in 7.1.1 and Figure 5.

When a metallic accessible part, to which the ESD pulse is to be applied, is available on the EUT, this part shall be connected to the HCP via the cable with bleeder resistors; see Figure 8.

7.1.3.2 Floor-standing equipment

Floor-standing equipment without any metallic connection to the ground reference plane shall be installed similarly to 7.1.2 and Figure 6.

A cable with bleeder resistors shall be used between the metallic accessible part, to which the ESD pulse is to be applied, and the ground reference plane (GRP); see Figure 9. 

7.2 Test set-up for post-installation tests

These tests are optional, and not mandatory for certification tests; they may be applied only when agreed between manufacturer and customer. It has to be considered that other co-located equipment may be unacceptably affected.

The equipment or system shall be tested in its final installed conditions.

In order to facilitate a connection for the discharge return cable, a ground reference plane shall be placed on the floor of the installation, close to the EUT at about 0,1 m distance. This plane should be of copper or aluminium not less than 0,25 mm thick. Other metallic materials may be used, providing the minimum thickness is 0,65 mm. The plane should be approximately 0,3 m wide, and 2 m in length where the installation allows.

This ground reference plane should be connected to the protective earthing system. Where this is not possible, it should be connected to the earthing terminal of the EUT, if available.

The discharge return cable of the ESD generator shall be connected to the reference plane at a point close to the EUT. Where the EUT is installed on a metal table, the table shall be connected to the reference plane via a cable with a 470 k Ω resistor located at each end, to prevent a build-up of charge.

An example of the set-up for post-installation tests is given in Figure 7.

8 Test procedure

8.1 Laboratory reference conditions

In order to minimize the impact of environmental parameters on test results, the tests shall be carried out in climatic and electromagnetic reference conditions as specified in 8.1.1 and 8.1.2.

8.1.1 Climatic conditions

In the case of air discharge testing, the climatic conditions shall be within the following ranges:

- ambient temperature: 15 °C to 35 °C;
- relative humidity: 30 % to 60 %;
- atmospheric pressure: 86 kPa (860 mbar) to 106 kPa (1 060 mbar).

NOTE Any other values are specified in the product specification.

The EUT shall be operated within its intended climatic conditions.

8.1.2 Electromagnetic conditions

The electromagnetic environment of the laboratory shall not influence the test results.

8.2 EUT exercising

The test programs and software shall be chosen so as to exercise all normal modes of operation of the EUT. The use of special exercising software is encouraged, but permitted only where it can be shown that the EUT is being comprehensively exercised.

For conformance testing, the EUT shall be continually operated in its most sensitive mode (program cycle) which shall be determined by preliminary testing.

If monitoring equipment is required, it should be decoupled in order to reduce the possibility of erroneous failure indication.

8.3 Execution of the test

The testing shall be performed by direct and indirect application of discharges to the EUT according to a test plan. This should include:

- representative operating conditions of the EUT;
- whether the EUT should be tested as tabletop or floor-standing;
- the points at which discharges are to be applied;
- at each point, whether contact or air discharges are to be applied;
- the test level to be applied;
- the number of discharges to be applied at each point for compliance testing;
- whether post-installation tests are also to be applied.

It may be necessary to carry out some investigatory testing to establish some aspects of the test plan.

8.3.1 Direct application of discharges to the EUT

Ⓐ) Unless stated otherwise in the generic, product-related or product-family standards, the static electricity discharges shall be applied only to those points and surfaces of the EUT which are accessible to persons during normal use. The following exclusions apply (i.e. discharges are not applied to those items):

- a) those points and surfaces which are only accessible under maintenance. In this case, special ESD mitigation procedures shall be given in the accompanying documentation;
- b) those points and surfaces which are only accessible under service by the (end-)user. Examples of these rarely accessed points are as follows: battery contacts while changing batteries, a cassette in a telephone answering machine, etc.;
- c) those points and surfaces of equipment which are no longer accessible after fixed installation or after following the instructions for use, for example, the bottom and/or wall-side of equipment or areas behind fitted connectors;
- d) the contacts of coaxial and multi-pin connectors which are provided with a metallic connector shell. In this case, contact discharges shall only be applied to the metallic shell of that connector.

Contacts within a non-conductive (for example, plastic) connector and which are accessible shall be tested by the air-discharge test only. This test shall be carried out by using the rounded tip finger on the ESD generator.

In general, six cases shall be considered:

| Case | Connector shell | Cover material | Air discharge to: | Contact discharge to: |
|------|-----------------|----------------|-------------------|-----------------------|
| 1 | Metallic | None | — | Shell |
| 2 | Metallic | Insulated | Cover | Shell when accessible |
| 3 | Metallic | Metallic | — | Shell and cover |
| 4 | Insulated | None | ^a | — |
| 5 | Insulated | Insulated | Cover | — |
| 6 | Insulated | Metallic | — | Cover |

NOTE In case a cover is applied to provide (ESD) shielding to the connector pins, an ESD warning label should be present on that cover or on the equipment near to that connector to which the cover is applied.

^a If the product (family) standard requires testing to individual pins of an insulated connector, air discharges shall apply.

- e) those contacts of connectors or other accessible parts that are ESD sensitive because of functional reasons and are provided with an ESD warning label, for example, r.f. inputs from measurement, receiving or other communication functions.

Rationale: Many connector ports are designed to handle high-frequency information, either analogue or digital, and therefore cannot be provided with sufficient overvoltage protection devices. In the case of analogue signals, bandpass filters may be a solution. Overvoltage protecting diodes have too much stray capacitance to be useful at the frequencies at which the EUT is designed to operate.

In all previous cases, special ESD mitigation procedures are recommended, to be given in the accompanying documentation. Ⓐ)

The test voltage shall be increased from the minimum to the selected test level, in order to determine any threshold of failure (see clause 5). The final test level should not exceed the product specification value in order to avoid damage to the equipment.

The test shall be performed with single discharges. On preselected points at least ten single discharges (in the most sensitive polarity) shall be applied.

For the time interval between successive single discharges an initial value of 1 s is recommended. Longer intervals may be necessary to determine whether a system failure has occurred.

NOTE The points to which the discharges should be applied may be selected by means of an exploration carried out at a repetition rate of 20 discharges per second, or more.

The ESD generator shall be held perpendicular to the surface to which the discharge is applied. This improves repeatability of the test results.

The discharge return cable of the generator shall be kept at a distance of at least 0,2 m from the EUT whilst the discharge is being applied.

In the case of contact discharges, the tip of the discharge electrode shall touch the EUT, before the discharge switch is operated.

In the case of painted surfaces covering a conducting substrate, the following procedure shall be adopted:

If the coating is not declared to be an insulating coating by the equipment manufacturer, then the pointed tip of the generator shall penetrate the coating so as to make contact with the conducting substrate. Coating declared as insulating by the manufacturer shall only be submitted to the air discharge. The contact discharge test shall not be applied to such surfaces.

In the case of air discharges, the round discharge tip of the discharge electrode shall be approached as fast as possible (without causing mechanical damage) to touch the EUT. After each discharge, the ESD generator (discharge electrode) shall be removed from the EUT. The generator is then retriggered for a new single discharge. This procedure shall be repeated until the discharges are completed. In the case of an air discharge test, the discharge switch, which is used for contact discharge, shall be closed.

8.3.2 Indirect application of the discharge

Discharges to objects placed or installed near the EUT shall be simulated by applying the discharges of the ESD generator to a coupling plane, in the contact discharge mode.

In addition to the test procedure described in 8.3.1, the requirements given in 8.3.2.1 and 8.3.2.2 shall be met.

8.3.2.1 Horizontal coupling plane (HCP) under the EUT

Discharge to the HCP shall be made horizontally to the edge of the HCP.

At least 10 single discharges (in the most sensitive polarity) shall be applied at the front edge of each HCP opposite the centre point of each unit (if applicable) of the EUT and 0,1 m from the front of the EUT. The long axis of the discharge electrode shall be in the plane of the HCP and perpendicular to its front edge during the discharge.

The discharge electrode shall be in contact with the edge of the HCP (see Figure 5).

In addition, consideration should be given to exposing all sides of the EUT to this test.

8.3.2.2 Vertical coupling plane

At least 10 single discharges (in the most sensitive polarity) shall be applied to the centre of one vertical edge of the coupling plane (Figure 5 and Figure 6). The coupling plane, of dimensions 0,5 m × 0,5 m, is placed parallel to, and positioned at a distance of 0,1 m from, the EUT.

Discharges shall be applied to the coupling plane, with sufficient different positions such that the four faces of the EUT are completely illuminated.

A₂ 9 Evaluation of test results

The test results shall be classified in terms of the loss of function or degradation of performance of the equipment under test, relative to a performance level defined by its manufacturer or the requestor of the test, or agreed between the manufacturer and the purchaser of the product. The recommended classification is as follows:

- a) normal performance within limits specified by the manufacturer, requestor or purchaser;
- b) temporary loss of function or degradation of performance which ceases after the disturbance ceases, and from which the equipment under test recovers its normal performance, without operator intervention;
- c) temporary loss of function or degradation of performance, the correction of which requires operator intervention;
- d) loss of function or degradation of performance which is not recoverable, owing to damage to hardware or software, or loss of data.

The manufacturer's specification may define effects on the EUT which may be considered insignificant, and therefore acceptable.

This classification may be used as a guide in formulating performance criteria, by committees responsible for generic, product and product-family standards, or as a framework for the agreement on performance criteria between the manufacturer and the purchaser, for example, where no suitable generic, product or product-family standard exists.

10 Test report

The test report shall contain all the information necessary to reproduce the test. In particular, the following shall be recorded:

- the items specified in the test plan required by clause 8 of this standard;
- identification of the EUT and any associated equipment, for example, brand name, product type, serial number;
- identification of the test equipment, for example, brand name, product type, serial number;
- any special environmental conditions in which the test was performed, for example, shielded enclosure;
- any specific conditions necessary to enable the test to be performed;
- performance level defined by the manufacturer, requestor or purchaser;
- performance criterion specified in the generic, product or product-family standard;
- any effects on the EUT observed during or after the application of the test disturbance, and the duration for which these effects persist;
- the rationale for the pass/fail decision (based on the performance criterion specified in the generic, product or product-family standard, or agreed between the manufacturer and the purchaser);
- any specific conditions of use, for example, cable length or type, shielding or grounding, or EUT operating conditions, which are required to achieve compliance. **A₂**

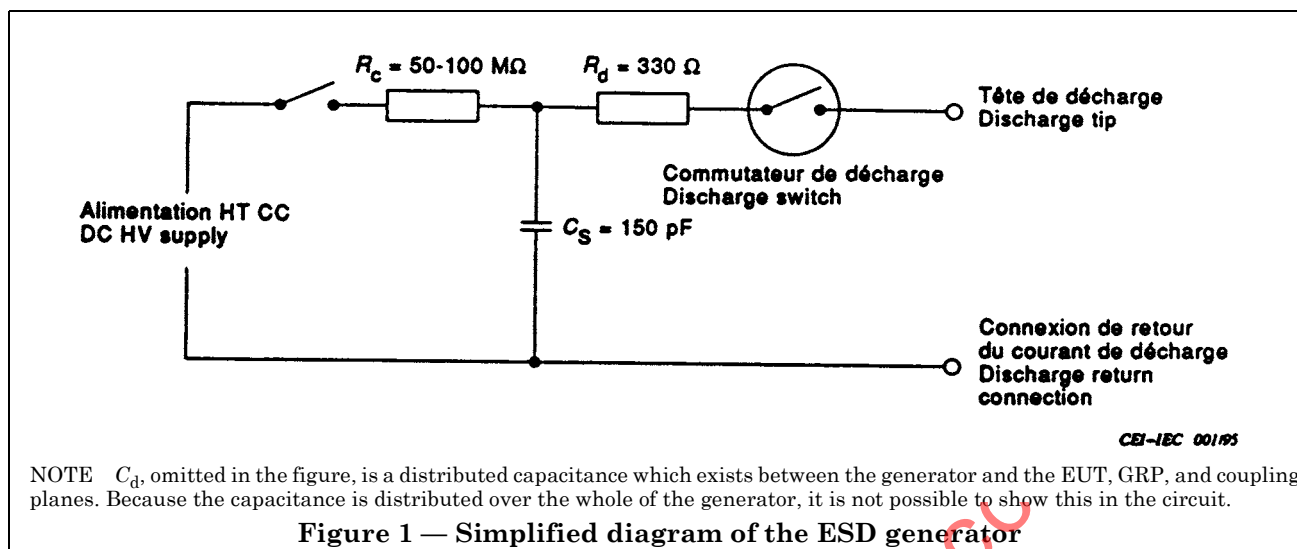

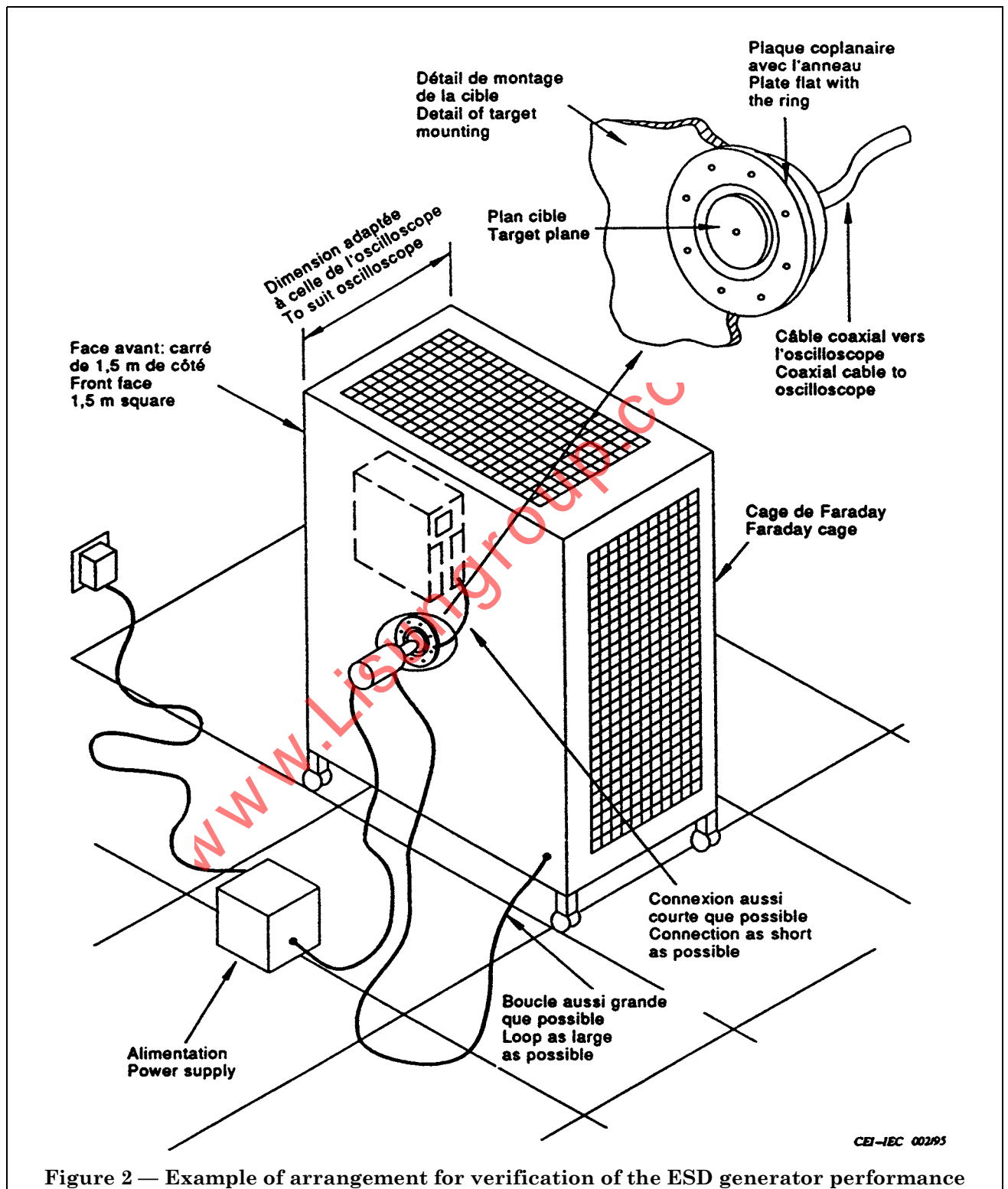
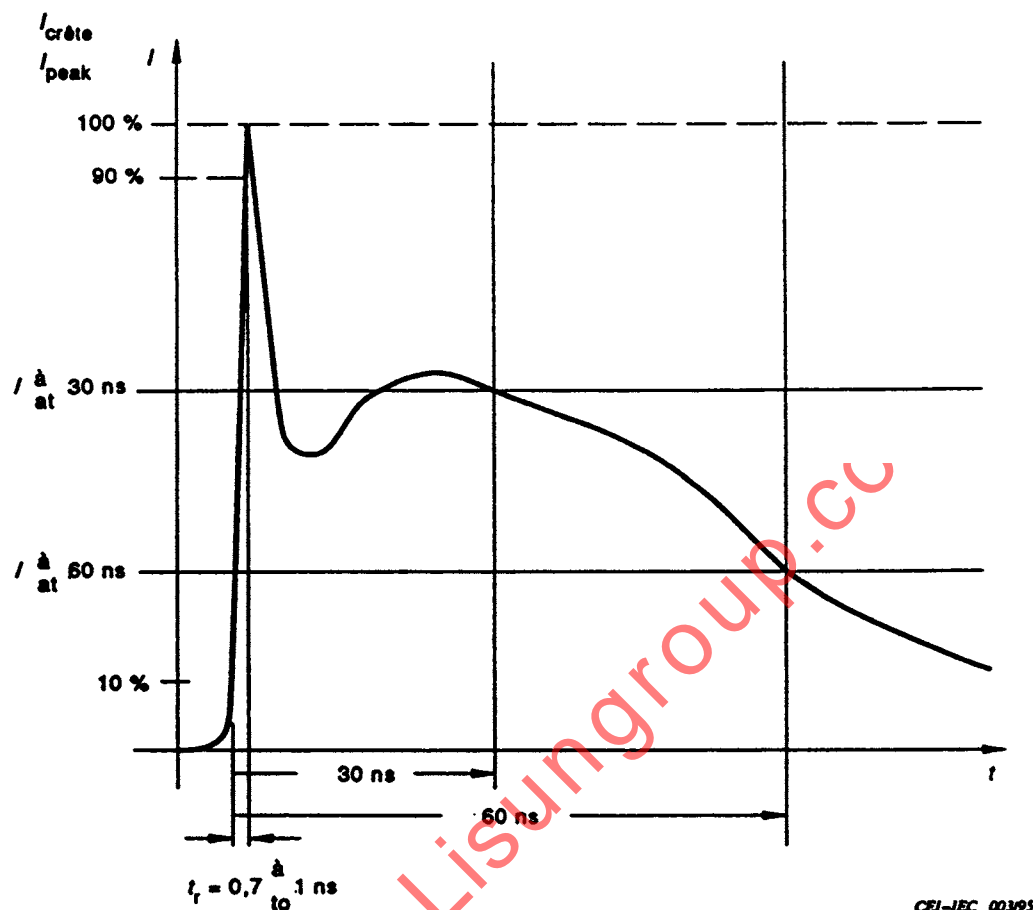

Figure 2 — Example of arrangement for verification of the ESD generator performance



Values are given in Table 2.

Figure 3 — Typical waveform of the output current of the ESD generator

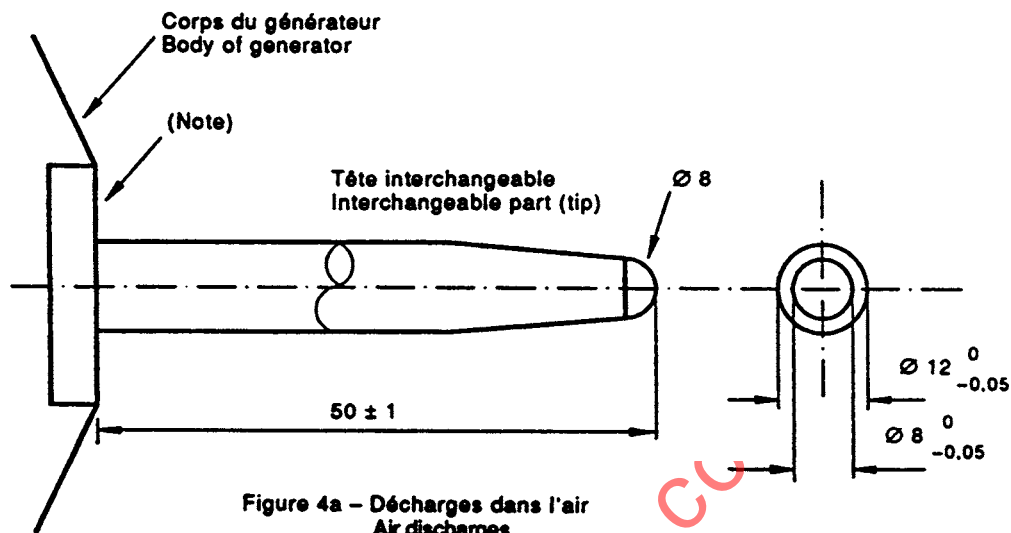

Figure 4a - Décharges dans l'air
Air discharges

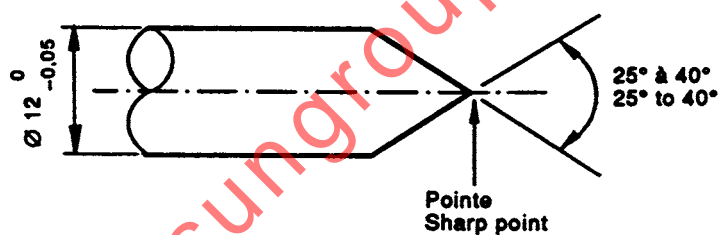

Figure 4b - Décharges au contact
Contact discharges

CEI-IEC 00495

Dimensions in millimetres

NOTE The discharge switch (e.g. vacuum relay) shall be mounted as close as possible to the tip of the discharge electrode.

Figure 4 — Discharge electrodes of the ESD generator

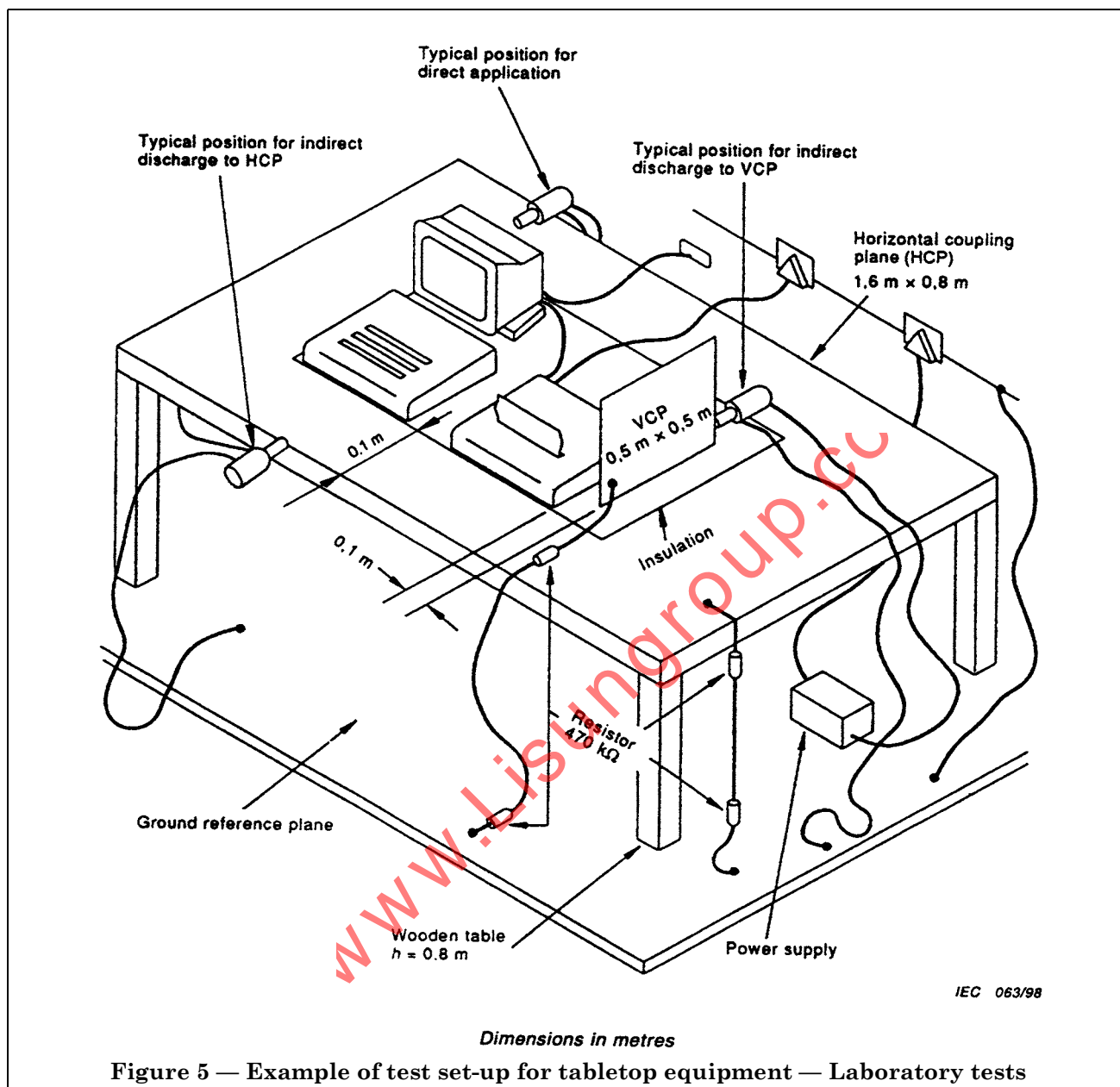

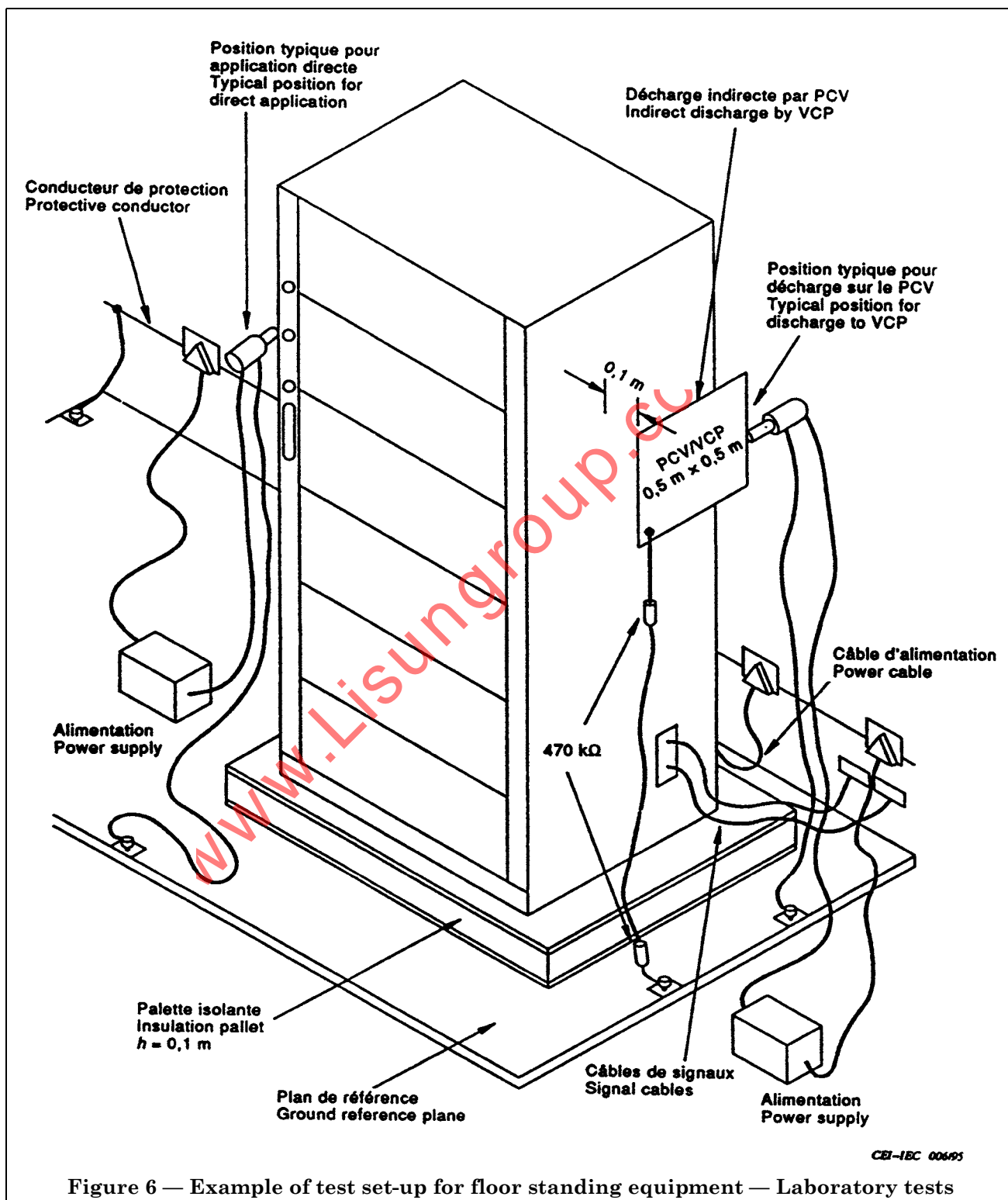

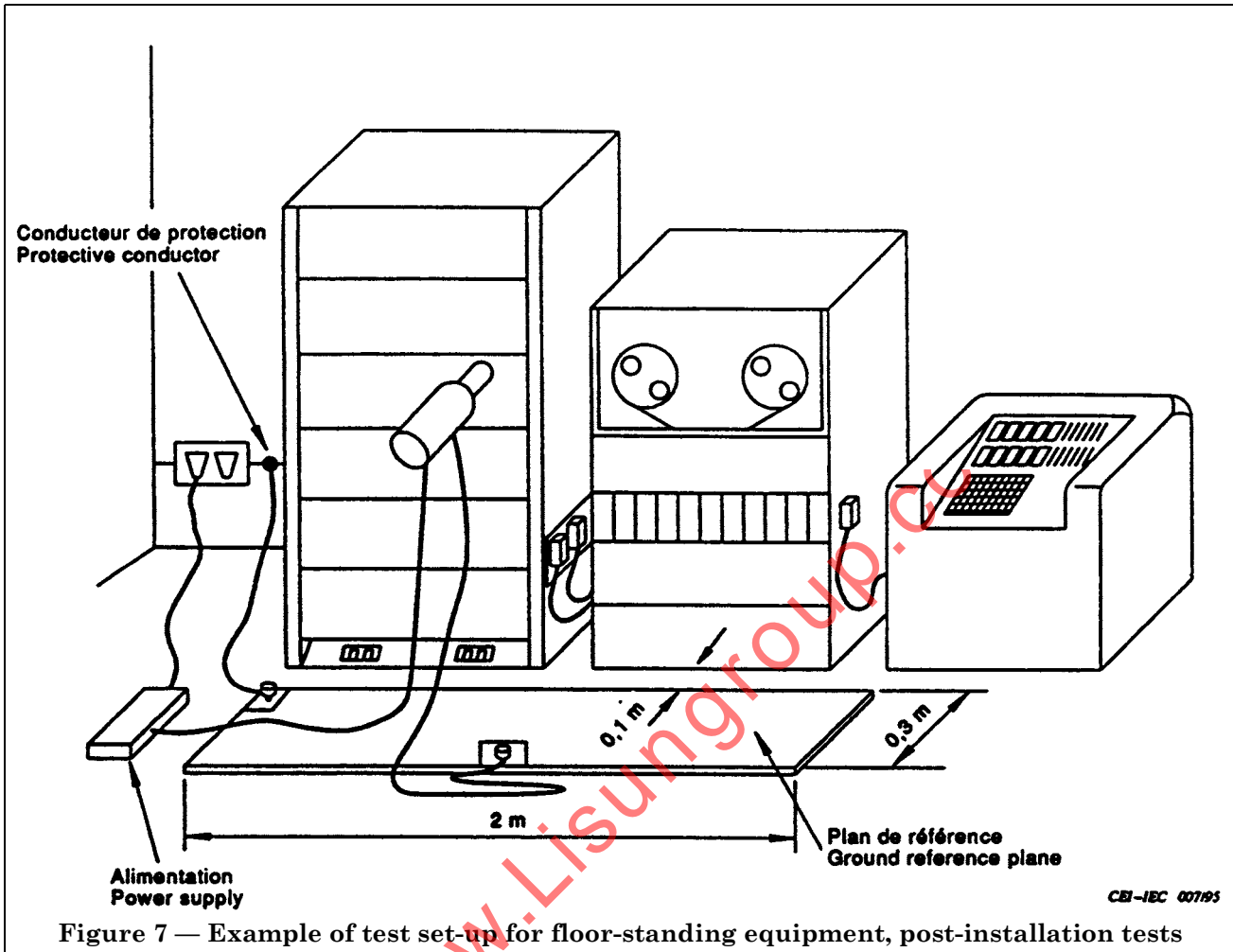

Figure 7 — Example of test set-up for floor-standing equipment, post-installation tests

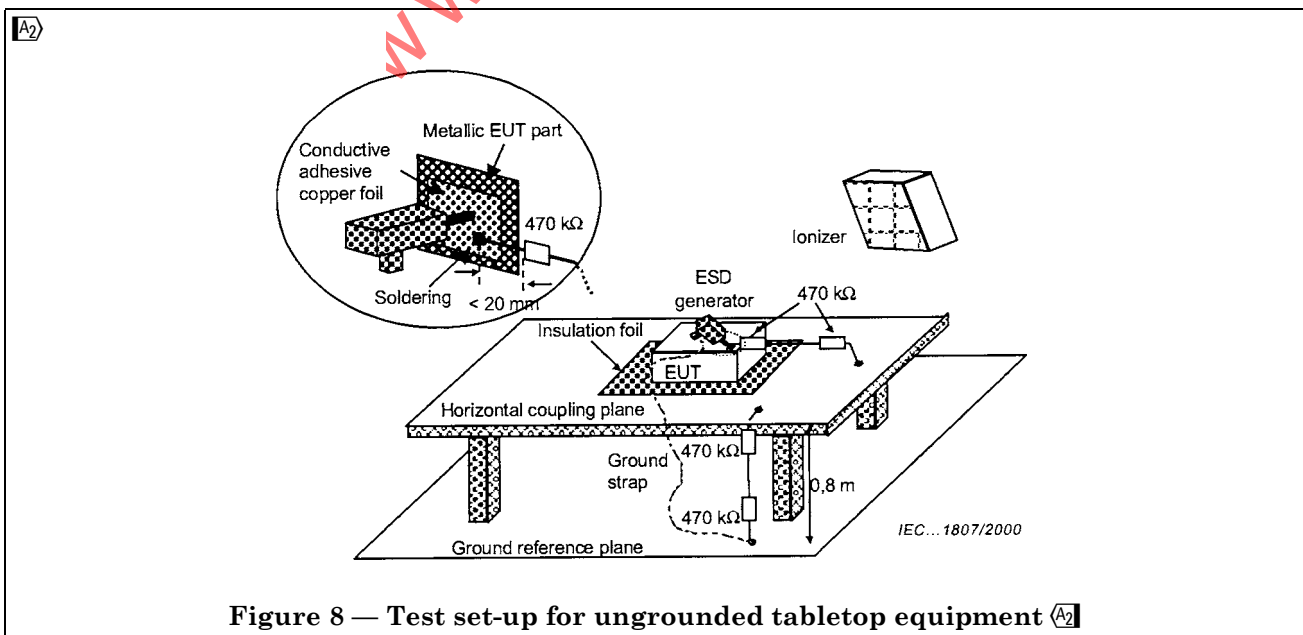
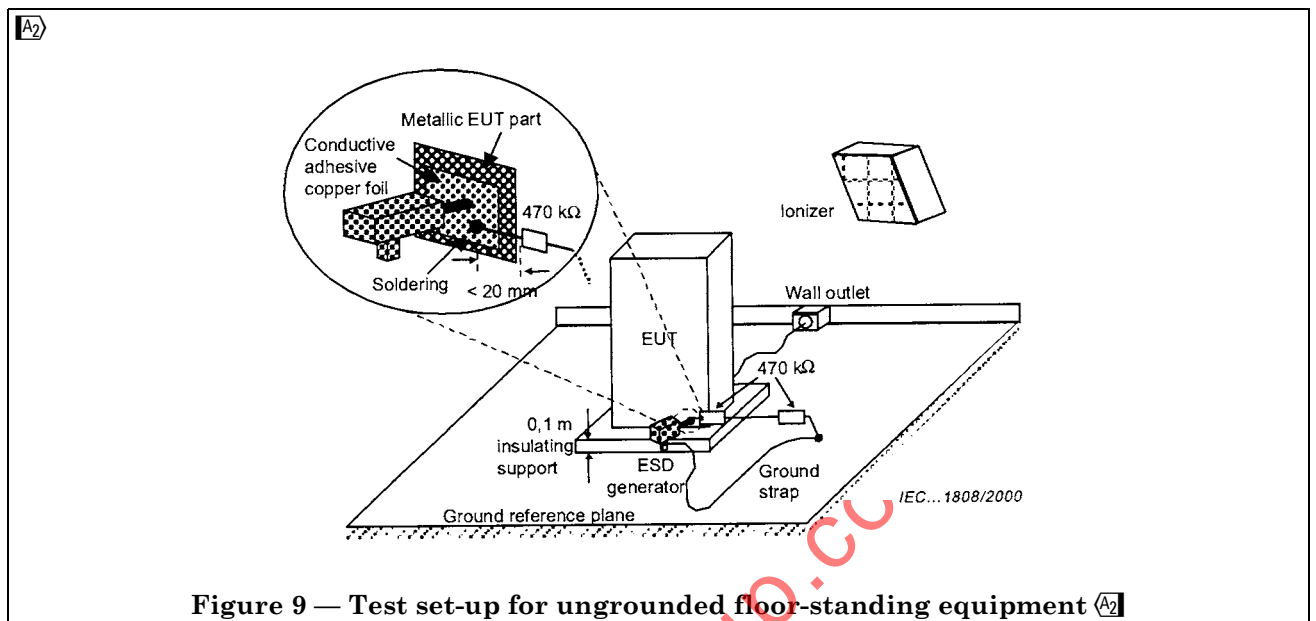

Figure 8 — Test set-up for ungrounded tabletop equipment A2



Annex A (informative) Explanatory notes

A.1 General considerations

The problem of protecting equipment against the discharge of static electricity has gained considerable importance for manufacturers and users.

The extensive use of microelectronic components has emphasized the need to define the aspects of the problem and to seek a solution in order to enhance products/system reliability.

The problem of static electricity accumulation and subsequent discharges becomes more relevant for uncontrolled environments and the widespread application of equipment and systems in a wide range of industrial plants.

Equipment may also be subjected to electromagnetic energies whenever discharges occur from personnel to nearby objects. Additionally, discharges can occur between metal objects, such as chairs and tables, in the proximity of equipment. However, based on limited experience available to date, it is considered that the tests described in this standard may adequately simulate the effects of the latter phenomenon. This aspect will be investigated and may lead to an amendment of this standard.

The effects of the operator discharge may be a simple malfunction of the equipment or damage of electronic components. The dominant effects can be attributed to the parameters of the discharge current (rise time, duration, etc.).

The knowledge of the problem and the necessity to have a tool to assist in the prevention of undesirable effects due to the discharge of static electricity on equipment, have initiated the development of the standard testing procedure described in this standard.

A.2 Influences of the environmental conditions on the levels of charge

The generation of electrostatic charges is especially favoured by the combination of synthetic fabrics and dry atmosphere. There are many possible variations in the charging process. A common situation is one in which an operator walks over a carpet and at each step loses or gains electrons from his body to the fabric. Friction between the operator's clothing and his chair can also produce an exchange of charges. The operator's body may be charged either directly or by electrostatic inductions; in the latter case a conducting carpet will give no protection unless the operator is adequately earthed to it.

The graphic representation of Figure A.1 shows the voltage values to which different fabrics may be charged depending, on the relative humidity of the atmosphere.

Equipment may be directly subjected to discharges of voltage values up to several kilovolts, depending on the type of synthetic fabric and the relative humidity of the environment.

A.3 Relationship of environmental levels to air and contact discharge

As a measurable quantity, static voltage levels found in user environments have been applied to define immunity requirements. However, it has been shown that energy transfer is a function of the discharge current rather than, as well as, of the electrostatic voltage existing prior to the discharge. Further, it has been found that the discharge current typically is less than proportional to the pre-discharge voltage in the higher level ranges.

Possible reasons for non-proportional relationship between pre-discharge voltage and discharge current are:

- The discharge of high-voltage charges typically should occur through a long arcing path which increases the rise time, hence keeping the higher spectral components of the discharge current less than proportional to the pre-discharge voltage.
- High charge voltage levels will more likely develop across a small capacitance, assuming the amount of charge should be constant for a typical charge generation event. Conversely, high charge voltages across a large capacitance would need a number of successive generation events which is less likely to occur. This means that the charge energy tends to become constant between the higher charge voltages found in the user environment.

As a conclusion from the above, the immunity requirements for a given user environment need to be defined in terms of discharge current amplitudes.

Having recognized this concept, the design of the tester is eased. Trade-off in the choice of tester charge voltage and discharge impedance can be applied to achieve desired discharge current amplitudes.

A.4 Selection of test levels

The test levels should be selected in accordance with the most realistic installation and environmental conditions; a guideline is given in Table A.1.

Table A.1 — Guideline for the selection of the test levels

| Class | Relative humidity as low as % | Antistatic material | Synthetic material | Maximum voltage kV |
|-------|-------------------------------|---------------------|--------------------|--------------------|
| 1 | 35 | x | x | 2 |
| 2 | 10 | x | x | 4 |
| 3 | 50 | | | 8 |
| 4 | 10 | | | 15 |

The installation and environmental classes recommended are related to the test levels outlined in clause 5 of this standard.

For some materials, for example wood, concrete and ceramic, the probable level is not greater than level 2.

NOTE It is important, when considering the selection of an appropriate test level for a particular environment, to understand the critical parameters of the ESD effect.

The most critical parameter is perhaps the rate of change of discharge current which may be obtained through a variety of combinations of charging voltage, peak discharge current and rise time.

For example, the required ESD stress for the 15 kV synthetic material environment is more than adequately covered by the 8 kV/30 A class 4 test using the ESD generator contact discharge defined in this standard.

However, in a very dry environment with synthetic materials, higher voltages than 15 kV occur.

In the case of testing equipment with insulating surfaces, the air discharge method with voltages up to 15 kV may be used.

A.5 Selection of test points

The test points to be considered may, for example, include the following locations as applicable:

- points on metallic sections of a cabinet which are electrically isolated from ground;
- any point in the control or keyboard area and any other point of man-machine communication, such as switches, knobs, buttons, and other operator-accessible areas;
- indicators, LEDs, slots, grilles, connector hoods, etc.

A.6 Technical rationale for the use of the contact discharge method

In general the reproducibility of the previous test method (air discharge) was influenced by, for example, the speed of approach of the discharge tip, humidity, and construction of the test equipment, leading to variations in pulse rise time and magnitude of the discharge current.

In previous designs of ESD testers, the ESD event was simulated by discharging a charged capacitor through a discharge tip onto the EUT, the discharge tip forming a spark gap at the surface of the EUT.

The spark is a very complicated physical phenomenon. It has been shown that with a moving spark gap the resulting rise time (or rising slope) of the discharge current can vary from less than 1 ns and more than 20 ns, as the approach speed is varied.

Keeping the approach speed constant does not result in constant rise time. For some voltage/speed combinations, the rise time still fluctuates by a factor of up to 30.

One proposed way to stabilize the rise time is to use a mechanically fixed spark gap. Although the rise time is stabilized with this method, it cannot be recommended because the resulting rise time is much slower than the rise time of the natural event to be simulated.

The high-frequency content of the real ESD event is not properly simulated with this method. Using various types of triggering devices (e.g. gas tubes or thyratrons) instead of the open spark, is another possibility, but such kinds of triggering devices produce rise times which are still too low compared to the rise times of the real ESD event.

The only triggering device known today which is able to produce repeatable and fast rising discharge currents is the relay. The relay should have sufficient voltage capability and a single contact (to avoid double discharges in the rising part). For higher voltages, vacuum relays prove to be useful. Experience shows that by using a relay as the triggering device, not only is the measured discharge pulse shape much more repeatable in its rising part, but also the test results with real EUTs are more reproducible.

Consequently the relay-driven impulse tester is a device that produces a specified current pulse (amplitude and rise time).

This current is related to the real ESD voltage, as described in clause A.3.

A.7 Selection of elements for the ESD generator

A storage capacitance shall be used which is representative of the capacitance of the human body. A nominal value of 150 pF has been determined suitable for this purpose.

A resistance of 330 Ω has been chosen to represent the source resistance of a human body holding a metallic object such as a key or tool. It has been shown that this metal discharge situation is sufficiently severe to represent all human discharges in the field.

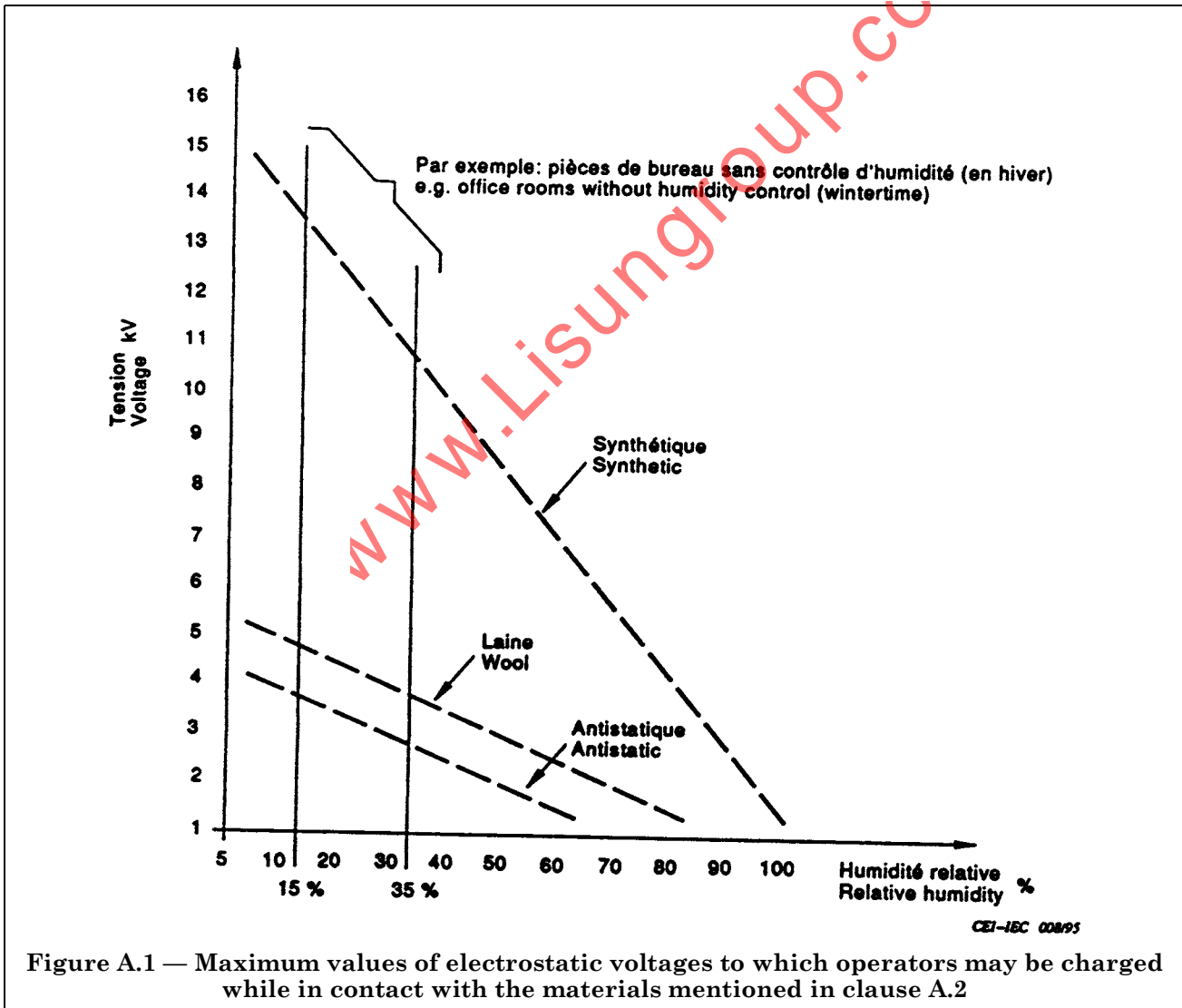

Figure A.1 — Maximum values of electrostatic voltages to which operators may be charged while in contact with the materials mentioned in clause A.2

Annex B (informative) Constructional details

B.1 Current-sensing transducer

The constructional details for a possible current-sensing transducer are shown in the Figure B.1 to Figure B.7.

The following sequence of assembly should be followed:

- 1) Solder the 25 load resistors "7" ($51\ \Omega$, 5 %, 0,25 W) onto the output side disc "3" and shave the soldered terminals.
- 2) Solder the 5 matching resistors "8" ($240\ \Omega$, 5 %, 0,25 W) in a pentagonal disposition onto the output connector, of Type N coaxial construction.
- 3) Assemble the output side disc "3", complete with load resistors, onto the output connector flange "1" using 4 screws M2,5 Pan Hd 6,5 mm long.
- 4) Assemble the output connector complete with matching resistors, "7" onto the output connector flange "1" using 4 screws M3.
- 5) Solder the input disc "4", with the screw support for electrode "6" screwed and soldered, on both the load and matching resistors group. Shave the soldered terminals.
- 6) Screw the flat electrode disc "5" on the screw support for electrode "6", then assemble the support for fixing "2" using 8 screws M3 Pan Hd 6,5 mm long.

B.2 Inductive current probe

Description and constructional details are under consideration.

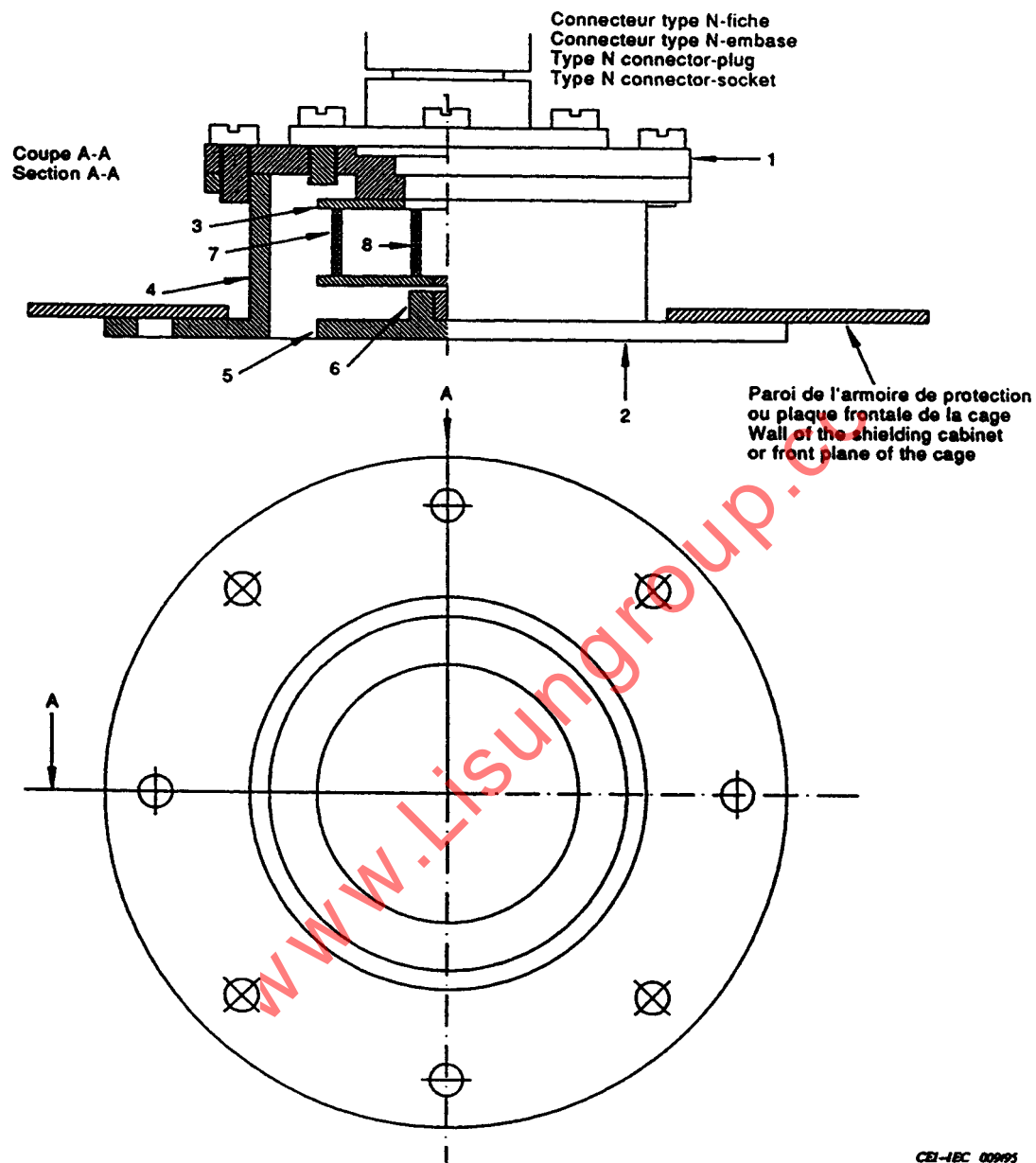

| Item | Qty | Screws | Qty |
|------|-----|----------------------------|-----|
| 1 | 1 | M3 PAN HD SC P 6,5 mm LG | 12 |
| 2 | 1 | | |
| 3 | 1 | | |
| 4 | 1 | | |
| 5 | 1 | M2,5 PAN HD SC P 5,0 mm LG | 3 |
| 6 | 1 | | |
| 7 | 25 | Resistor 51 Ω | |
| 8 | 5 | Resistor 240 Ω | |

Figure B.1 — Constructional details of the resistive load

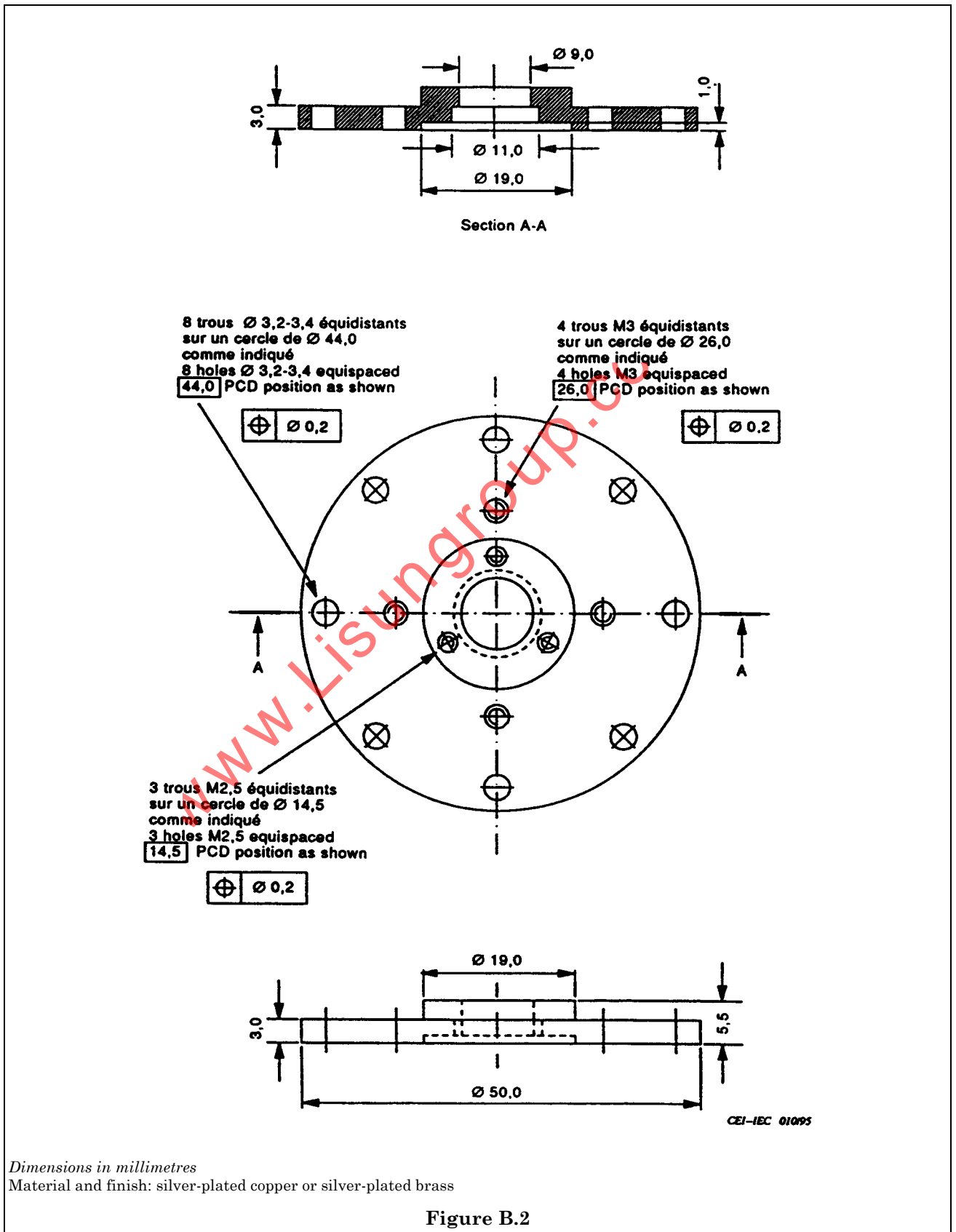

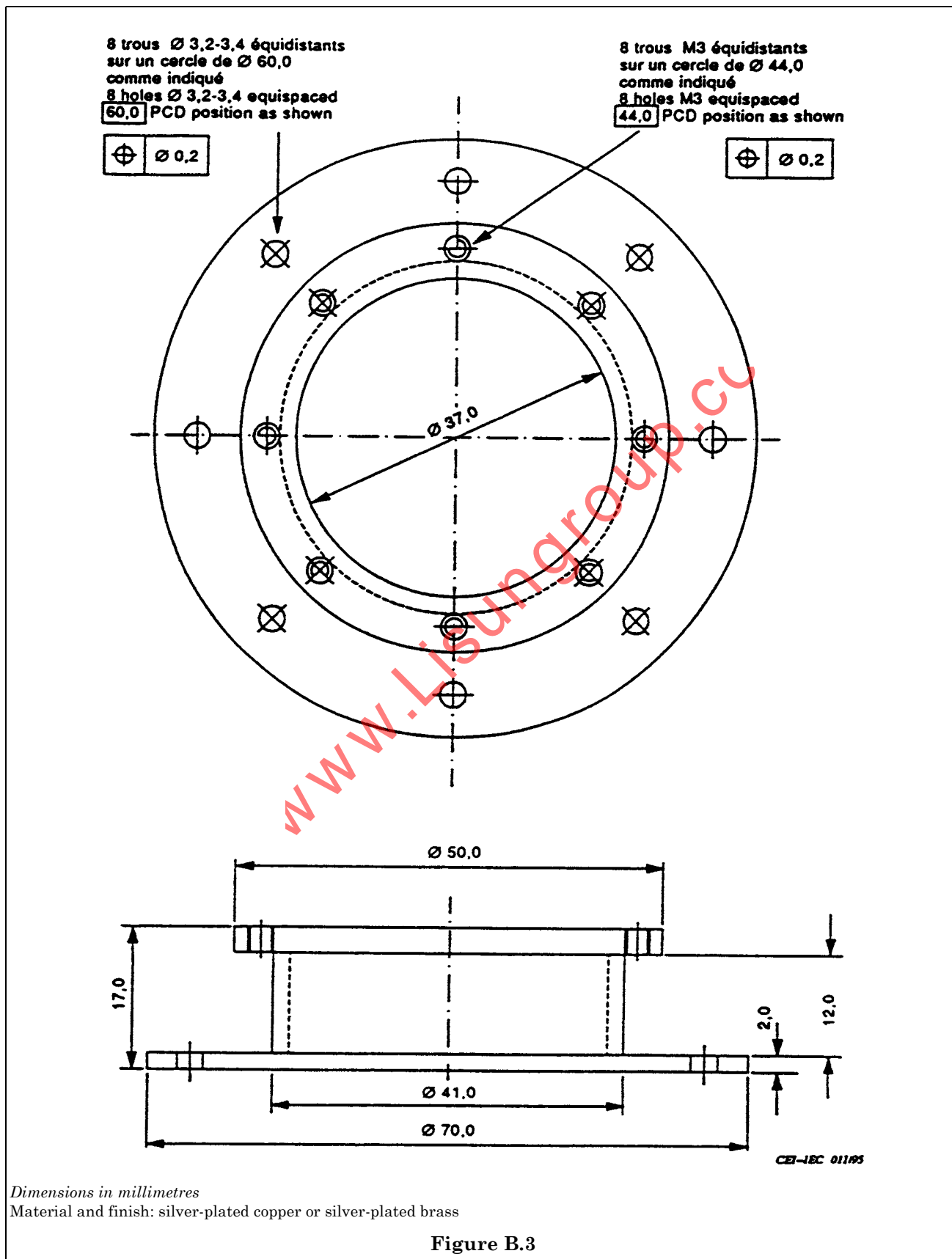

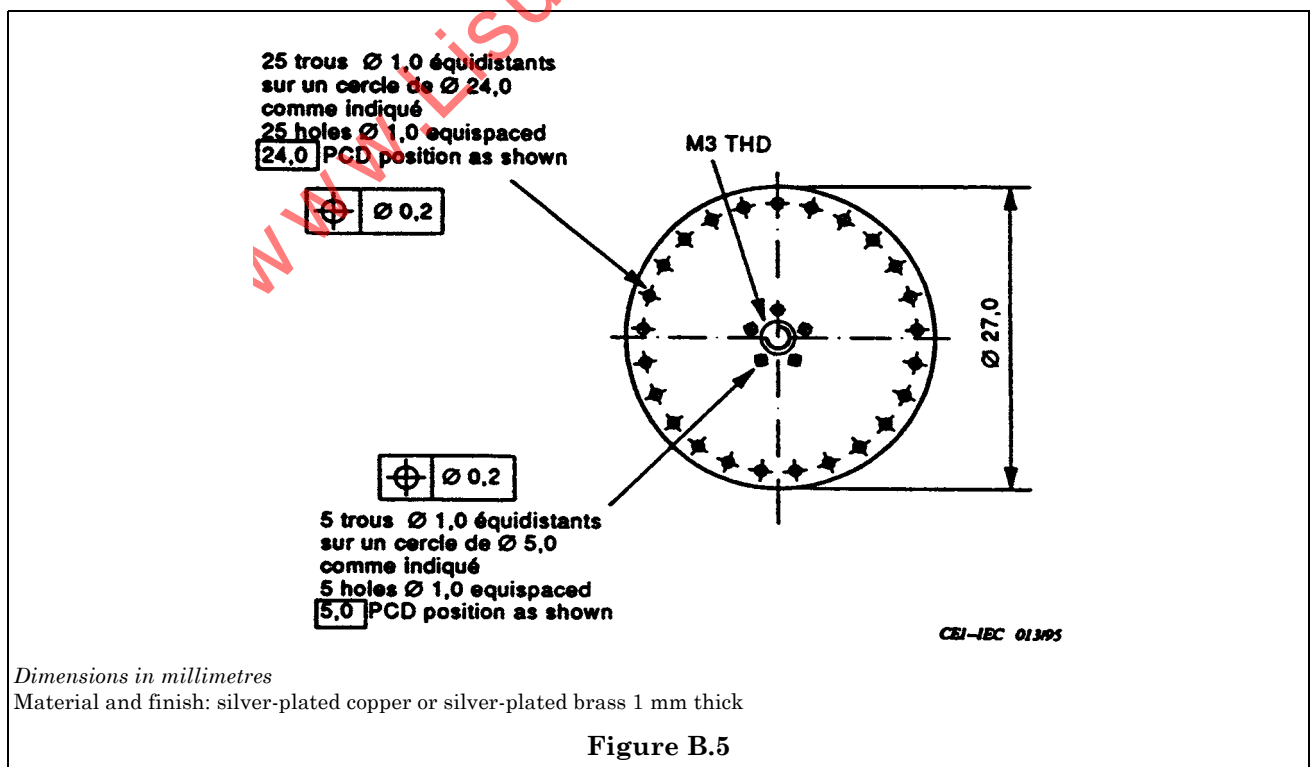
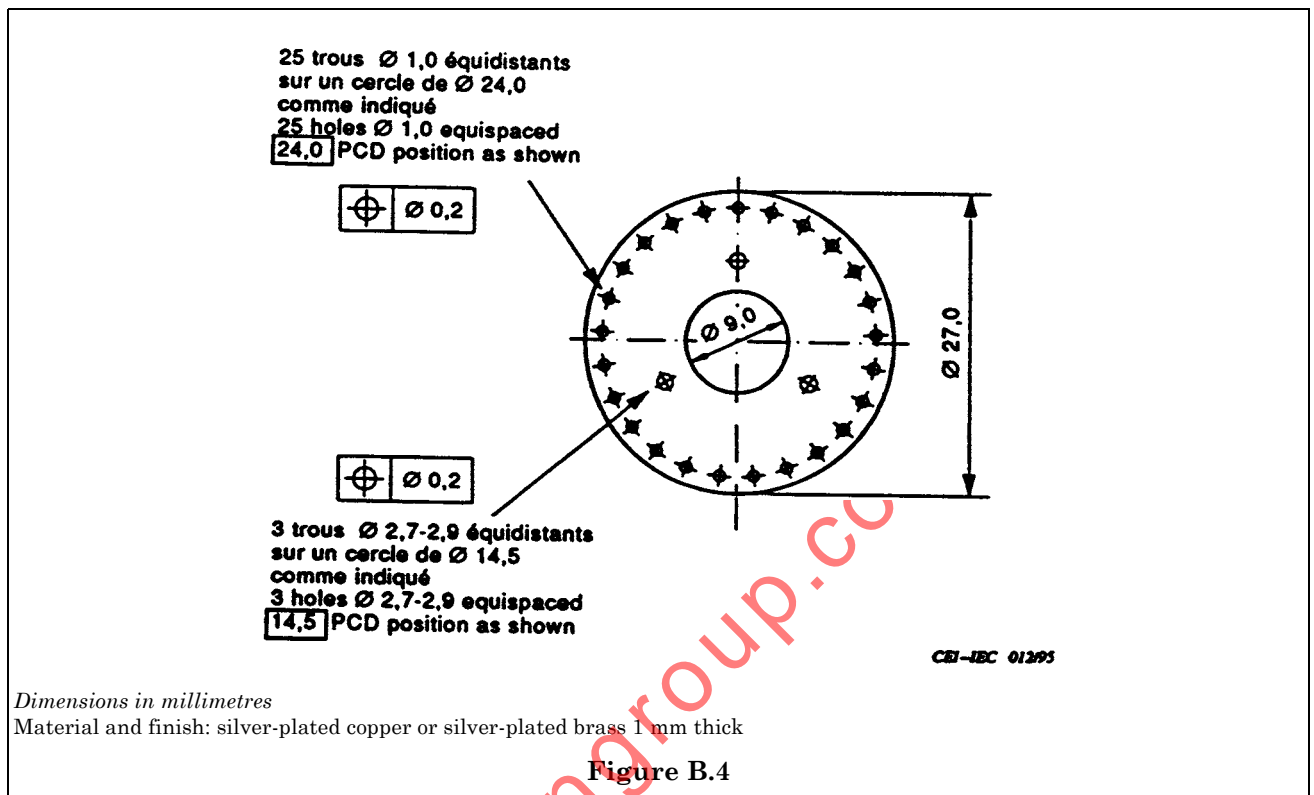

Ecrou M3 soudé sur le disque
M3 nut soldered on the disk

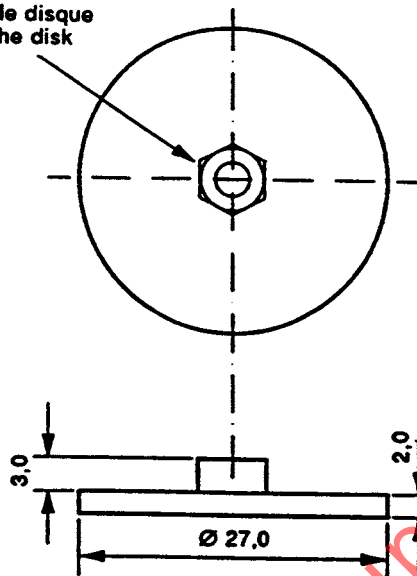

CBI-IEC 01495

Dimensions in millimetres

Material and finish: silver-plated copper or silver-plated brass

Figure B.6

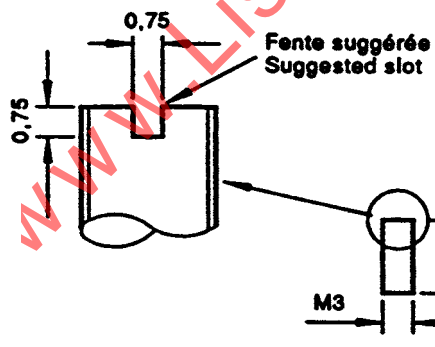

CBI-IEC 01595

Dimensions in millimetres

Material and finish: silver-plated copper or silver-plated brass

Figure B.7

Annex ZA (normative)**Other international publications quoted in this standard with the references of the relevant European publications**

This European Standard incorporates by date or undated reference, provisions from other publications. These normative references are cited at the appropriate places in the text and the publications are listed hereafter. For dated references, subsequent amendments to or revisions of any of these publications apply to this European Standard only when incorporated in it by amendment or revision. For undated references the latest edition of the publication referred to applies.

NOTE When the international publication has been modified by CENELEC common modifications, indicated by (mod), the relevant EN/HD applies.

| IEC publication | Date | Title | EN/HD | Date |
|-----------------|------|---|--------------------------|------|
| 50(161) | 1990 | <i>International Electrotechnical Vocabulary (IEV) Chapter 161: Electromagnetic compatibility</i> | — | — |
| 68-1 | 1988 | <i>Environmental testing — Part 1: General and guidance</i> | EN 60068-1 ¹⁾ | 1994 |

www.Lisungroup.cc

¹⁾ EN 60068-1 includes the corrigendum October 1988 and A1:1992 to IEC 68-1.

BSI — British Standards Institution

BSI is the independent national body responsible for preparing British Standards. It presents the UK view on standards in Europe and at the international level. It is incorporated by Royal Charter.

Revisions

British Standards are updated by amendment or revision. Users of British Standards should make sure that they possess the latest amendments or editions.

It is the constant aim of BSI to improve the quality of our products and services. We would be grateful if anyone finding an inaccuracy or ambiguity while using this British Standard would inform the Secretary of the technical committee responsible, the identity of which can be found on the inside front cover. Tel: 020 8996 9000. Fax: 020 8996 7400.

BSI offers members an individual updating service called PLUS which ensures that subscribers automatically receive the latest editions of standards.

Buying standards

Orders for all BSI, international and foreign standards publications should be addressed to Customer Services. Tel: 020 8996 9001. Fax: 020 8996 7001. Standards are also available from the BSI website at <http://www.bsi-global.com>.

In response to orders for international standards, it is BSI policy to supply the BSI implementation of those that have been published as British Standards, unless otherwise requested.

Information on standards

BSI provides a wide range of information on national, European and international standards through its Library and its Technical Help to Exporters Service. Various BSI electronic information services are also available which give details on all its products and services. Contact the Information Centre. Tel: 020 8996 7111. Fax: 020 8996 7048.

Subscribing members of BSI are kept up to date with standards developments and receive substantial discounts on the purchase price of standards. For details of these and other benefits contact Membership Administration. Tel: 020 8996 7002. Fax: 020 8996 7001. Further information about BSI is available on the BSI website at <http://www.bsi-global.com>.

Copyright

Copyright subsists in all BSI publications. BSI also holds the copyright, in the UK, of the publications of the international standardization bodies. Except as permitted under the Copyright, Designs and Patents Act 1988 no extract may be reproduced, stored in a retrieval system or transmitted in any form or by any means – electronic, photocopying, recording or otherwise – without prior written permission from BSI.

This does not preclude the free use, in the course of implementing the standard, of necessary details such as symbols, and size, type or grade designations. If these details are to be used for any other purpose than implementation then the prior written permission of BSI must be obtained.

If permission is granted, the terms may include royalty payments or a licensing agreement. Details and advice can be obtained from the Copyright Manager. Tel: 020 8996 7070.